

Mach3 USB Motion Card (AKZ250) Installation Manual

Ver1.17 (Date of document updates:2012/11/2)

Features:

- ✧ Supports all Mach3 versions, including the Mach3 R3.042.040 version.
- ✧ Supporting Windows series, including Windows2000/XP/Vista/Windows7.
- ✧ No need to install any USB drivers,it can be used aftr plugging in the computer.
- ✧ Full support for USB hot-swappable, the card is Monitoring USB connection status at any time.
- ✧ Supports Mach3 software limitationand backlash functions.
- ✧ Maximum step-pulse frequency is 200KHz, which is suitable for the servo or stepping motor.
- ✧ Status indicator LED can be useful to show the USB connection, and working status by flashing.
- ✧ 16 general-purpose inputs, with indicators.

- ✧ Feed rate, spindle speed rate, or jog rate can by controlled by the adjustment-knob.
- ✧ With on-board isolated power supply, external power supply is not needed.
External power can also be supplied to reduce USB load.

- ✧ 10 high-speed optocouplers with 10MHz, 24 general optocouplers for isolating all of the input/ output signals, this high-cost design can be provided high performance and stable system.
- ✧ Real-time speed chart and spindle speed changes can be observed



Contents

Revisions List

Basic connection diagram (an Overview)

Mechanical dimensions diagram

1. Prepare
2. Setup for Mach3
3. Setup motion card Hardware
4. Motion card connection Table
5. Motion card connection Diagram
6. Adjustment-knob
7. Spindle speed PWM output
8. Measure the rotating speed of the spindle
9. Auto tool zero
10. MPG Setup
11. Read-ahead buffer setting



Basic connection diagram (an Overview)

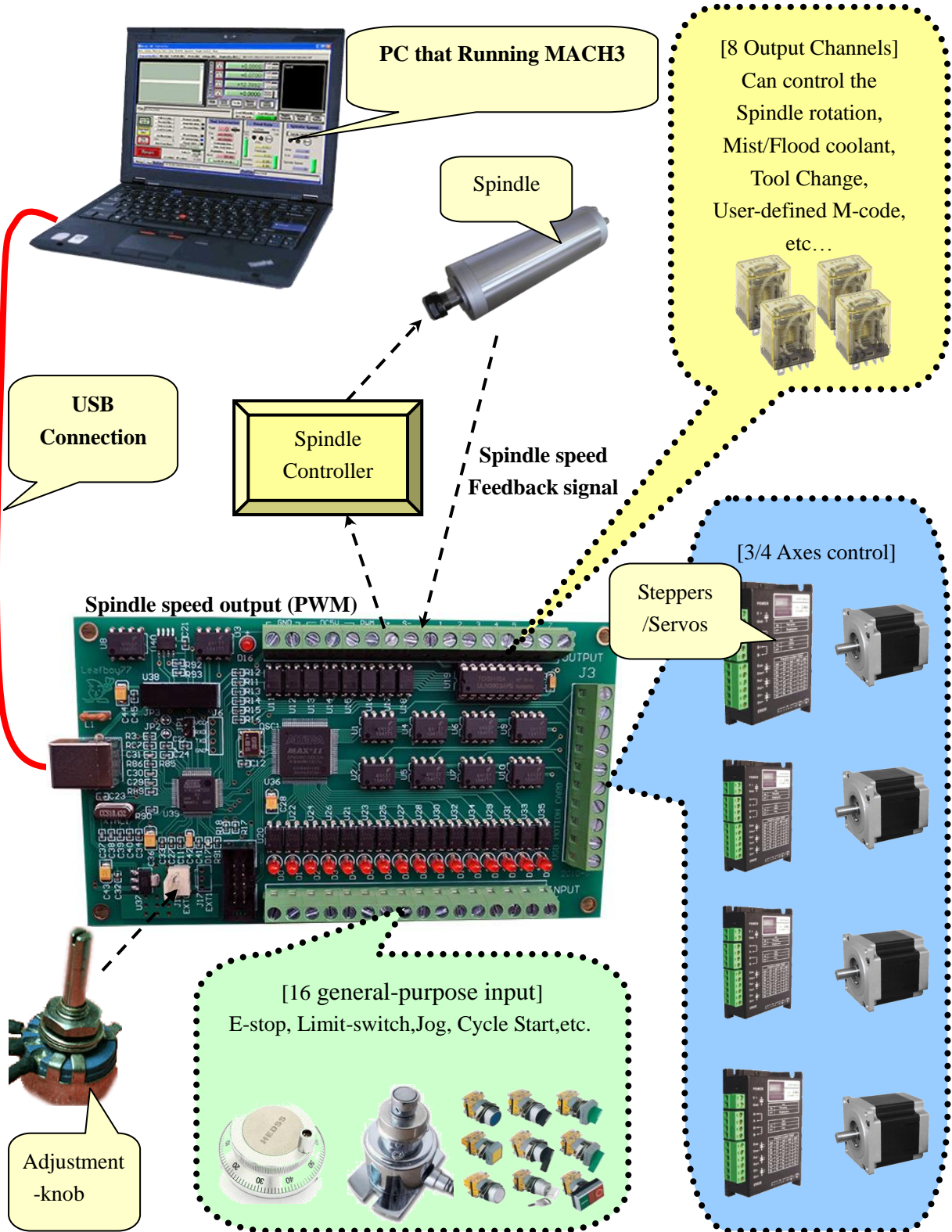



Mechanical dimensions diagram

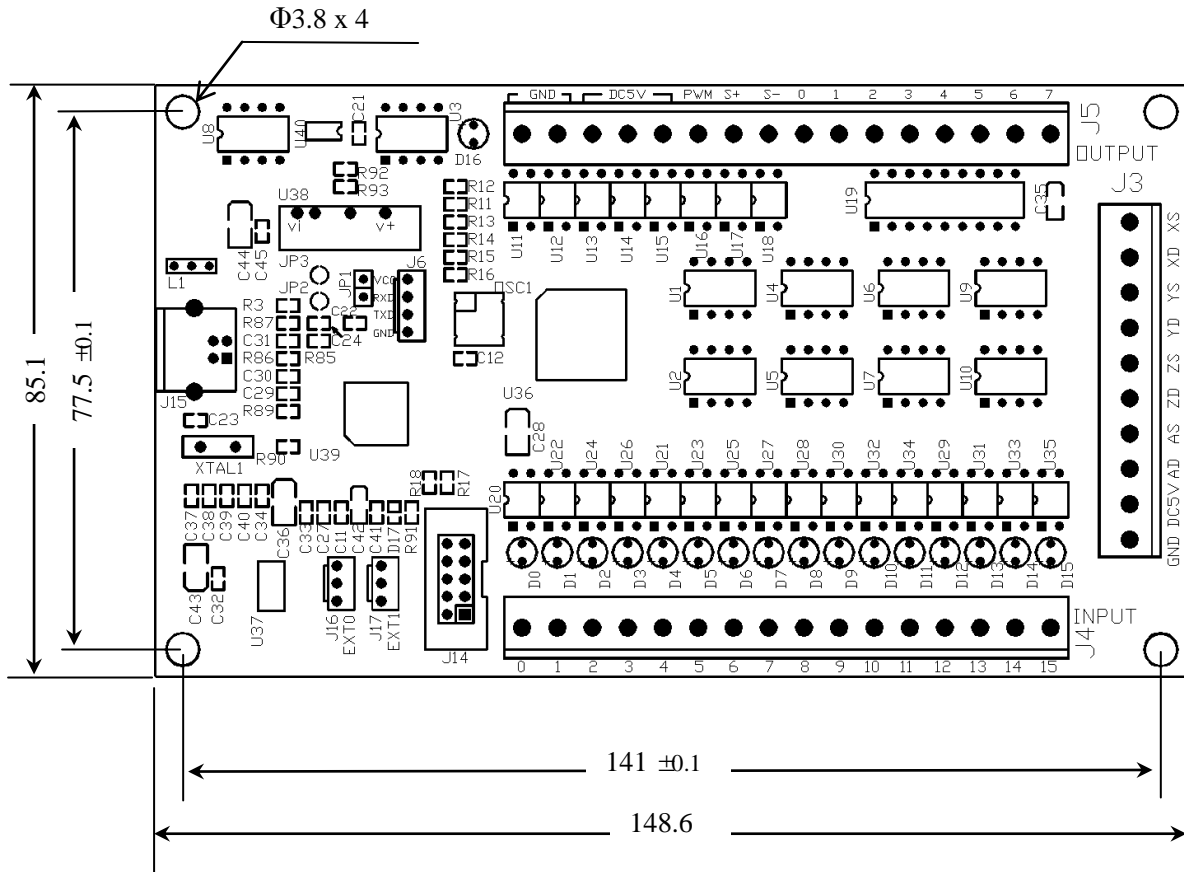

1. Prepare

1.1 Prepare Mach3 software



The latest version of Mach3 official website:
<http://www.machsupport.com/downloads.php>

Mach3 download: as shown below:



Downloads

For previous versions of Mach and LazyCam, XML's, and other Extra Information: [Click Here](#)

(Some of the older files are linked directly from the FTP server in order to avoid redundancy. If your download does not start immediately, please give it a few seconds - it's probably trying to contact/login to the FTP server.)

Mach

Mach3 is the flagship of the ArtSoft products. It is released in two versions: a Lockdown version, and a Development version. The Lockdown is a stable, static release recommended for new users, or people trialing the software. The Development version contains developing features and is released quite often so people can obtain new (but untested) features and capabilities. Both releases are limited to 500 lines of Gcode until licensed. Mach3 has a limit of 10,000,000 lines of Gcode even after licensing.

You must use a Desktop PC running a 32-bit version of Windows if you are using the Mach3 Parallel Port Driver. Laptops are not supported because the power saving features of the chipsets disrupt the pulse stream. Mach3 will only be supported on laptops running an external motion controller, such as one of those found on the [Plugins](#) page.

Lockdown:

Mach3 R3.042.040

Mach3 Changelog

Install Mach3:

This card does not require the parallel port driver.

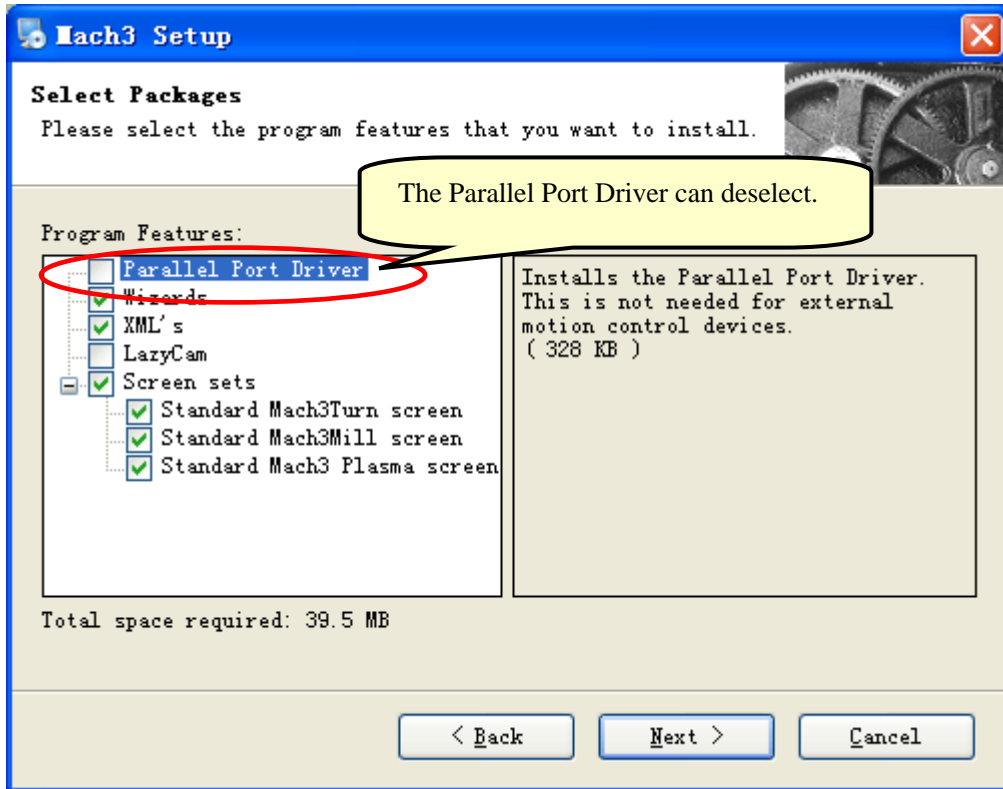

1.2 USB cable Prepare

Magnet ring installed in the USB cable at both ends



Attention

Use of acceptable quality USB cable

1.3 Installation the software of the USB motion card

This USB motion card does not need install any USB driver, Windows2000/Xp/Vista/Windows7 can directly identify.

1.3.1 Connecting the USB cable to the PC and the motion card.

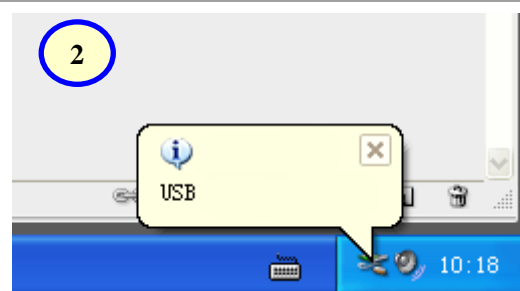

When the status indicator (LED) lights on the card, USB connection is successful.

1.3.2 Unzip the usbmove.zip, copy or drag usbmove.dll into your Mach3\PlugIns folder.

Note: Download the latest version of plug-in(usbmove.zip) in

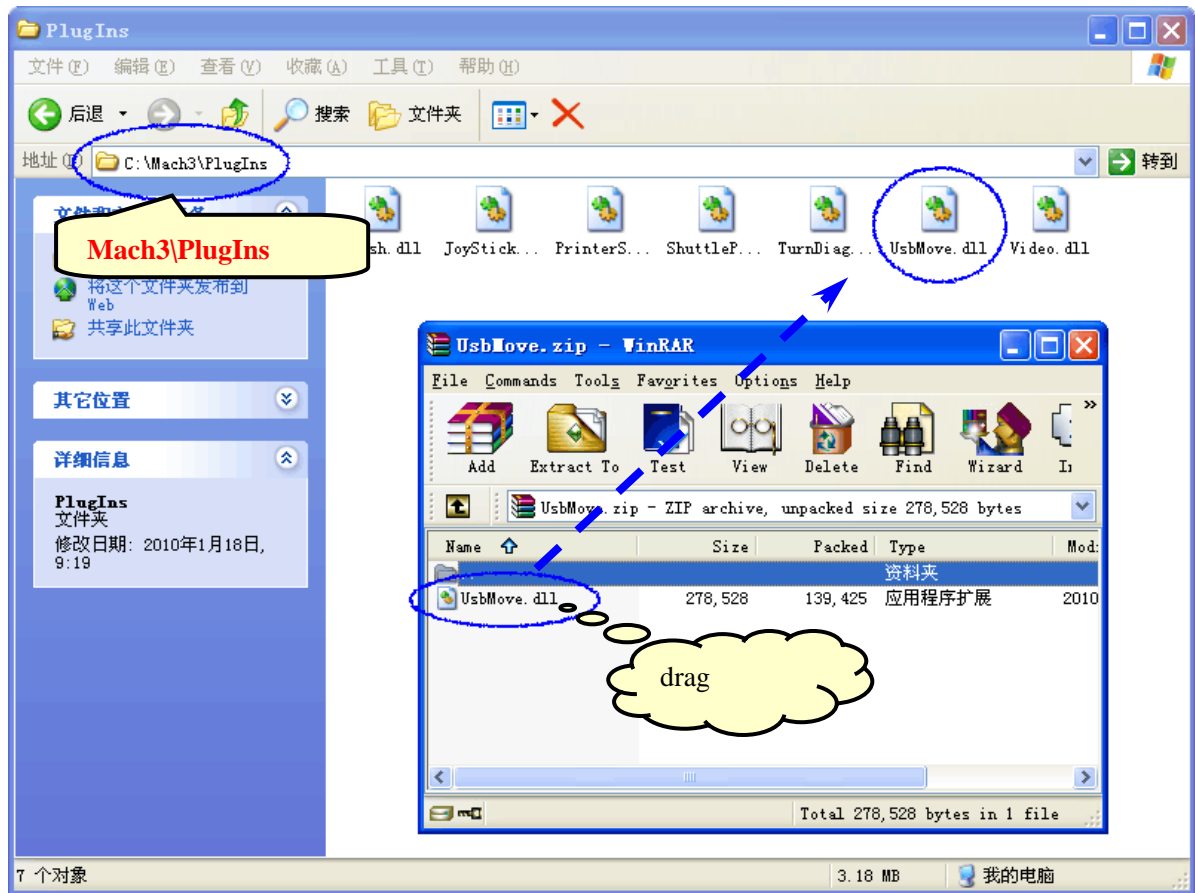

1.3.3 Start the Mach3 software, a dialogue of “Motion Control Hardware PlugIn sensed!!” is shown. Please select the “Mach3-USB-Motion-Card”, you can also check “Don't ask me this again”.

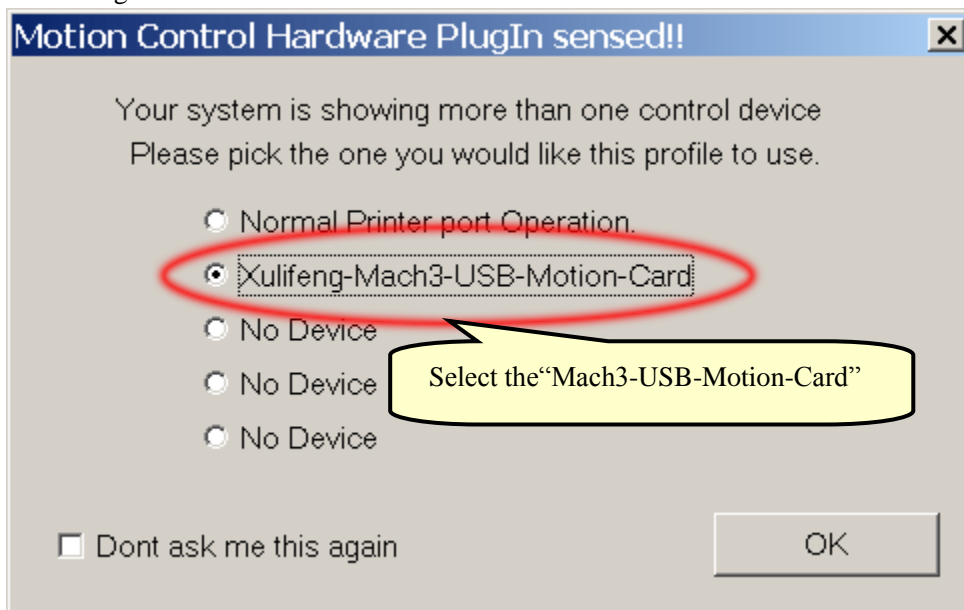

When the Mach3 is connecting with the card, the Status indicator (LED on the card) is flashing.

2. Setup for Mach3

2.1 Mach3 X、Y、Z、A Axis config as shown below: (Config => Ports and Pins)

Signal	Enabled	Step Pin#	Dir Pin#	Dir Low	Step Lo...	Step Port	Dir Port
X Axis	<input checked="" type="checkbox"/>	2	3	<input checked="" type="checkbox"/>	<input checked="" type="checkbox"/>	1	1
Y Axis	<input checked="" type="checkbox"/>	4	5	<input checked="" type="checkbox"/>	<input checked="" type="checkbox"/>	1	1
Z Axis	<input checked="" type="checkbox"/>	6	7	<input checked="" type="checkbox"/>	<input checked="" type="checkbox"/>	1	1
A Axis	<input checked="" type="checkbox"/>	8	9	<input checked="" type="checkbox"/>	<input checked="" type="checkbox"/>	1	1
B Axis	<input type="checkbox"/>	0	0	<input type="checkbox"/>	<input type="checkbox"/>	0	0
C Axis	<input type="checkbox"/>	0	0	<input type="checkbox"/>	<input type="checkbox"/>	0	0
Spindle	<input type="checkbox"/>	14		<input type="checkbox"/>	<input type="checkbox"/>		

2.2 Motor tuning setup as shown below: (Config => Motor Tuning)

Mach3 steps per unit:

Mach3 steps per unit = Mach3 steps per rev * Motor revs per unit

2.3 The Mach3 Menu => Config => Homing/Limits dialog
 Axes direction, depends on the “Reversed”.

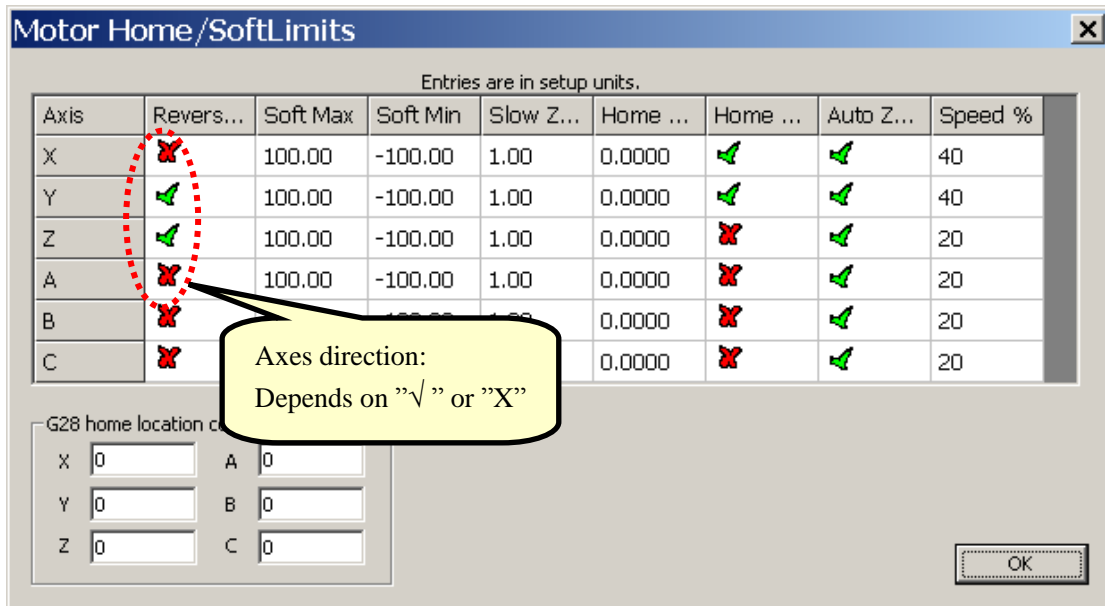

2.4 Setup the input singles.

There are 16 general-purpose input channels. The channels number is from 0 to 15(at J4).
Suggest Active Low = "X" (Set High signal Level for Inputs)

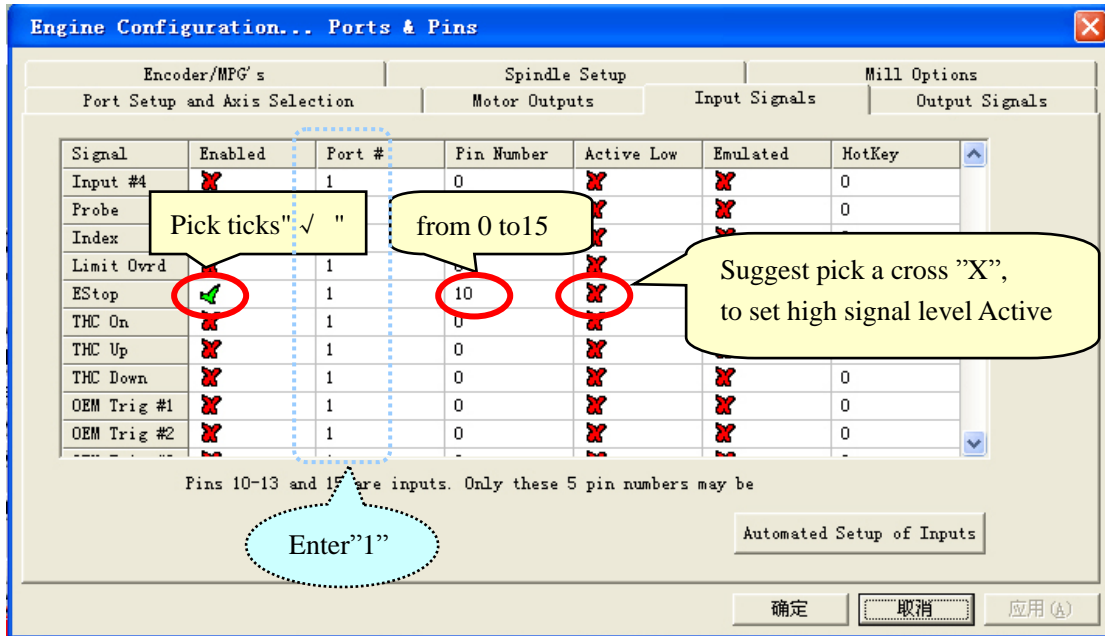

2.5 Setup the Output signals.

There are 8 general-purpose (open-drain) output channels,
The channels number is from 0 to 7 (at J5).
Suggest Active Low = "√" (Set Low signal Level for outputs)

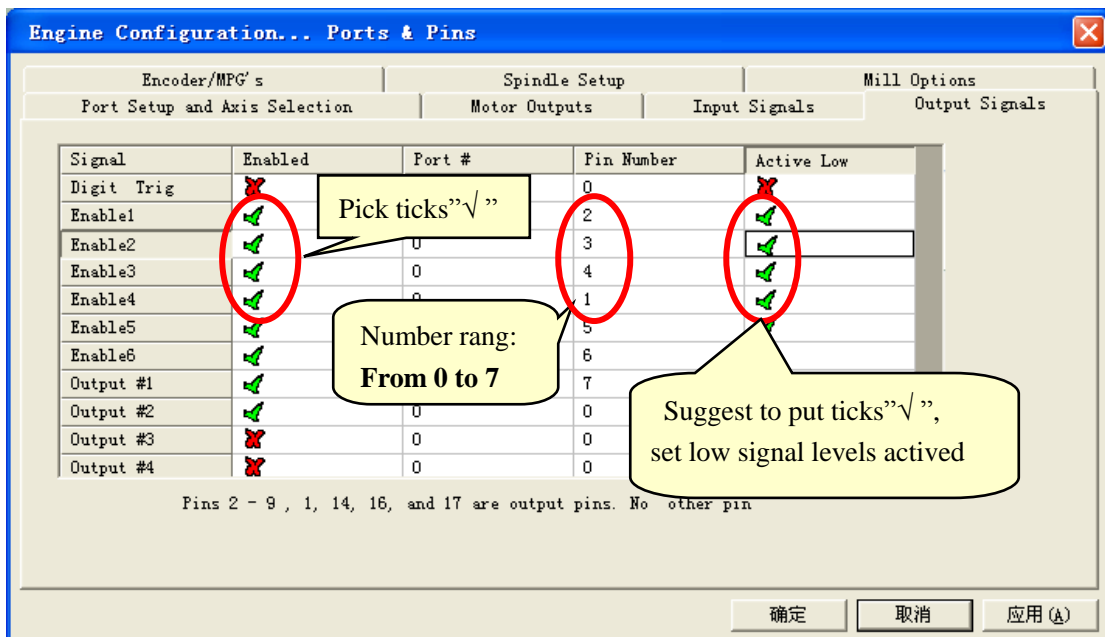

3. Setup motion card Hardware

The board is used USB power source, with isolated power source module, external power supply is not requested.

All outputs, including 4 axes pulse/DIR/8 output controls/Spindle-speed PWM output, are set to be high-impedance state (Hi-Z) when USB is connected. When running Mach3, Level is controlled by Mach3.

Suggest: All output signals in Mach3 can be set to be Active Low.

3.1 4 axis output signals, please refer to J3signals indicating.

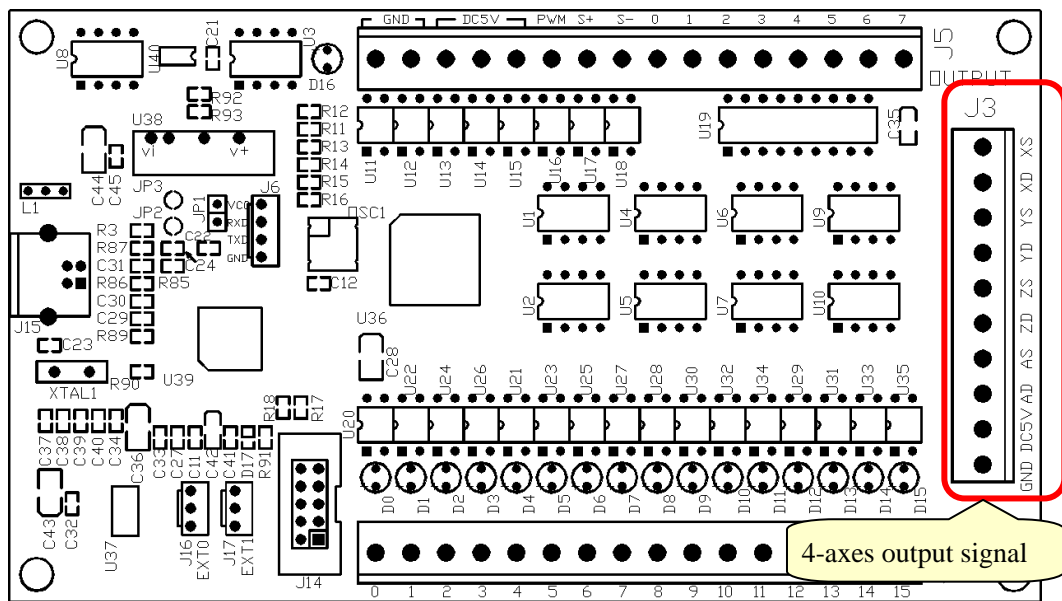

4-axes and Spindle PWM outputs

Schematic

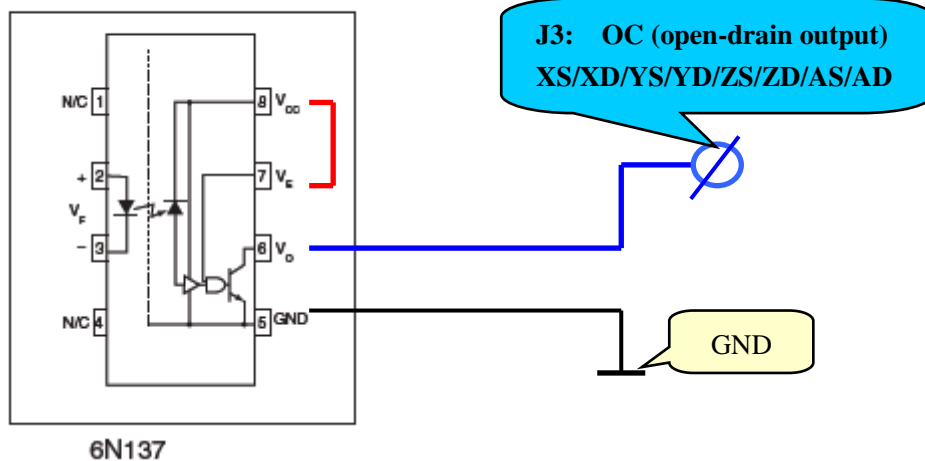

3.2 16 general-inputs, input voltage 5V(current:7mA). Wired on J4.

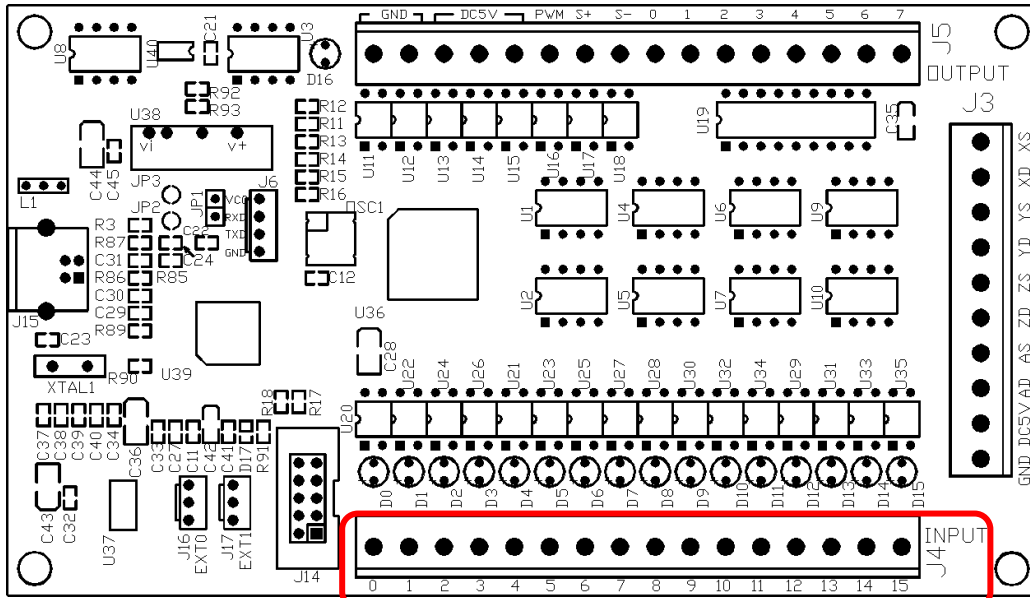

16 general-inputs, 330Ω resistor onboard



16-general-inputs Schematic

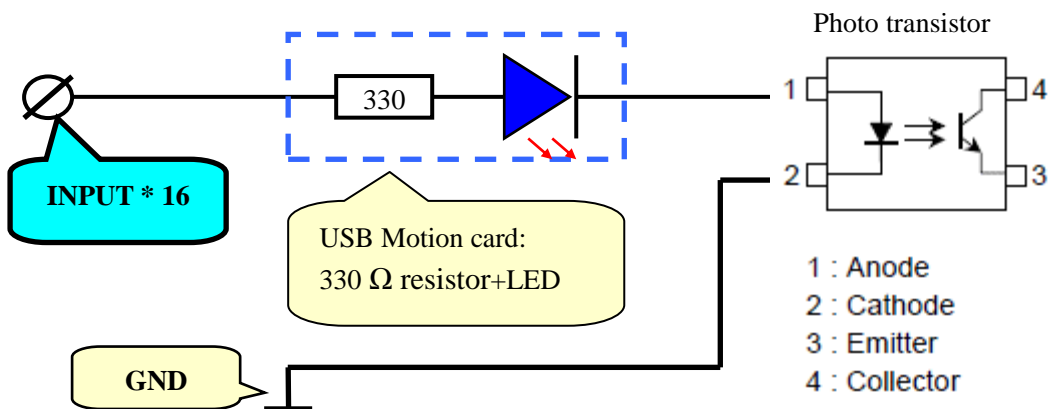

3.3 8 general-outputs, wiring of the 0、1、2、3、4、5、6、7 on J5.

Maximum Load voltage=24V / current=500mA, When output Low (turn on), otherwise the output is high-impedance state (Hi-Z).

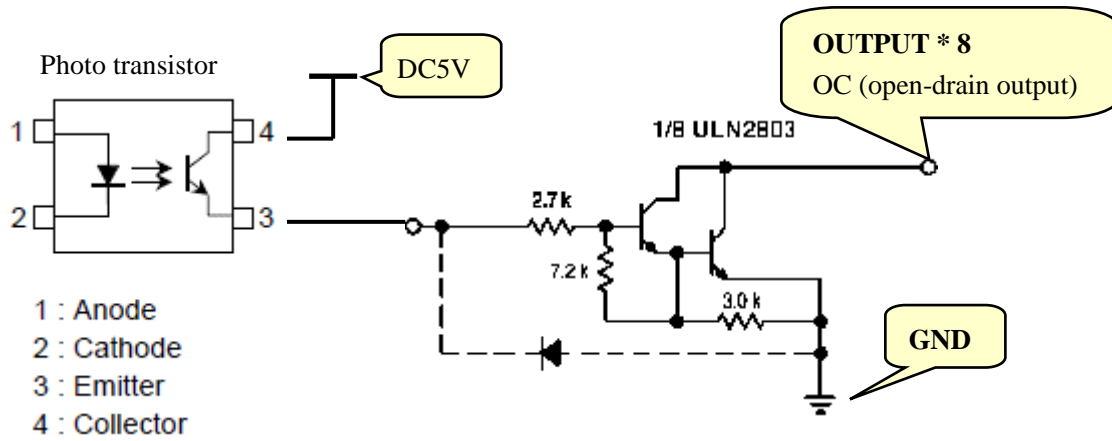

8 general-outputs, wiring of the 0、1、2、3、4、5、6、7 on J5.

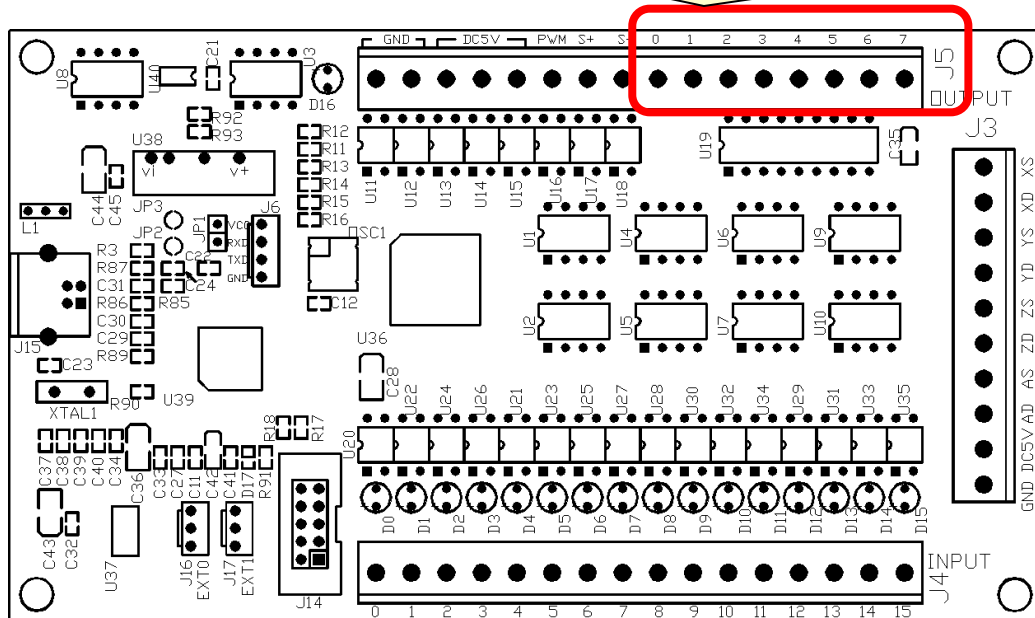

4 Motion card connection Table

4.1 4-axes

J3

GND	DC5V	AD	AS	ZD	ZS	YD	YS	XD	XS
-----	------	----	----	----	----	----	----	----	----

Pin Name	Function	Electrical	Description
GND	GND	GND	Signal Ground
DC5V	5V DC Output	Max=120mA	On-board isolated power module output
AD	A Direction	OC, 12V/13mA	A axis Direction Signal
AS	A Stepping	OC, 12V/13mA	A axis Stepping (Pulse) Signal
ZD	Z Direction	OC, 12V/13mA	Z axis Direction Signal
ZS	Z Stepping	OC, 12V/13mA	Z axis Stepping (Pulse) Signal
YD	Y Direction	OC, 12V/13mA	Y axis Direction Signal
YS	Y Stepping	OC, 12V/13mA	Y axis Stepping (Pulse) Signal
XD	X Direction	OC, 12V/13mA	X axis Direction Signal
XS	X Stepping	OC, 12V/13mA	X axis Stepping (Pulse) Signal

4.2 16-Inputs

J4

0	1	2	3	4	5	6	7	8	9	10	11	12	13	14	15
---	---	---	---	---	---	---	---	---	---	----	----	----	----	----	----

Pin number	Function	Electrical	Description
0	General-purpose Input / MPG Input	5V Max:7mA	general-purpose “0”,”1” Input / or Manual Pulse Generator (AB) Input
1			
2	General-purpose Input		Functions are set by Mach3 “Config”=>”Ports and Pins” =>”Input Signals”
3			
4			
5			
6			
7			
8			
9			
10			
11			
12			
13			
14			
15			

4.4 Output

J5

GND	GND	DC5V	DC5V	DC5V	PWM	S+	S-	0	1	2	3	4	5	6	7
-----	-----	------	------	------	-----	----	----	---	---	---	---	---	---	---	---

Pin Name	Function	Electrical	Description
GND	GND	GND	Signal Ground
GND			
DC5V	5V DC output	Max=120mA	On-board isolated power module output
DC5V			
DC5V			
PWM	Pulse-Width Modulation	OC, 12V/13mA	Spindle speed Control (Output)
S+	LED Positive input	6mA	Spindle speed Measure (Input)
S-	LED Negative input		
0	8 general-purpose (open-drain) output channels	Max=24V /500mA OC (open-drain)	Functions are set by Mach3 "Config"=>"Ports and Pins" => "Output Signals"
1			
2			
3			
4			
5			
6			
7			



Note:

1. "DC5V" is on-board isolated power module output. Voltage:5V, max current **120mA**.
2. "OC ": open-drain output

5 Motion card connection Diagram

5.1 X、Y、Z、A axes output. Optical power supply: Internal(on board) or External.

5.1.1 Using Internal(on board) power supply to drive.

Please install suitable resistance according to your setpping/servo driver need.

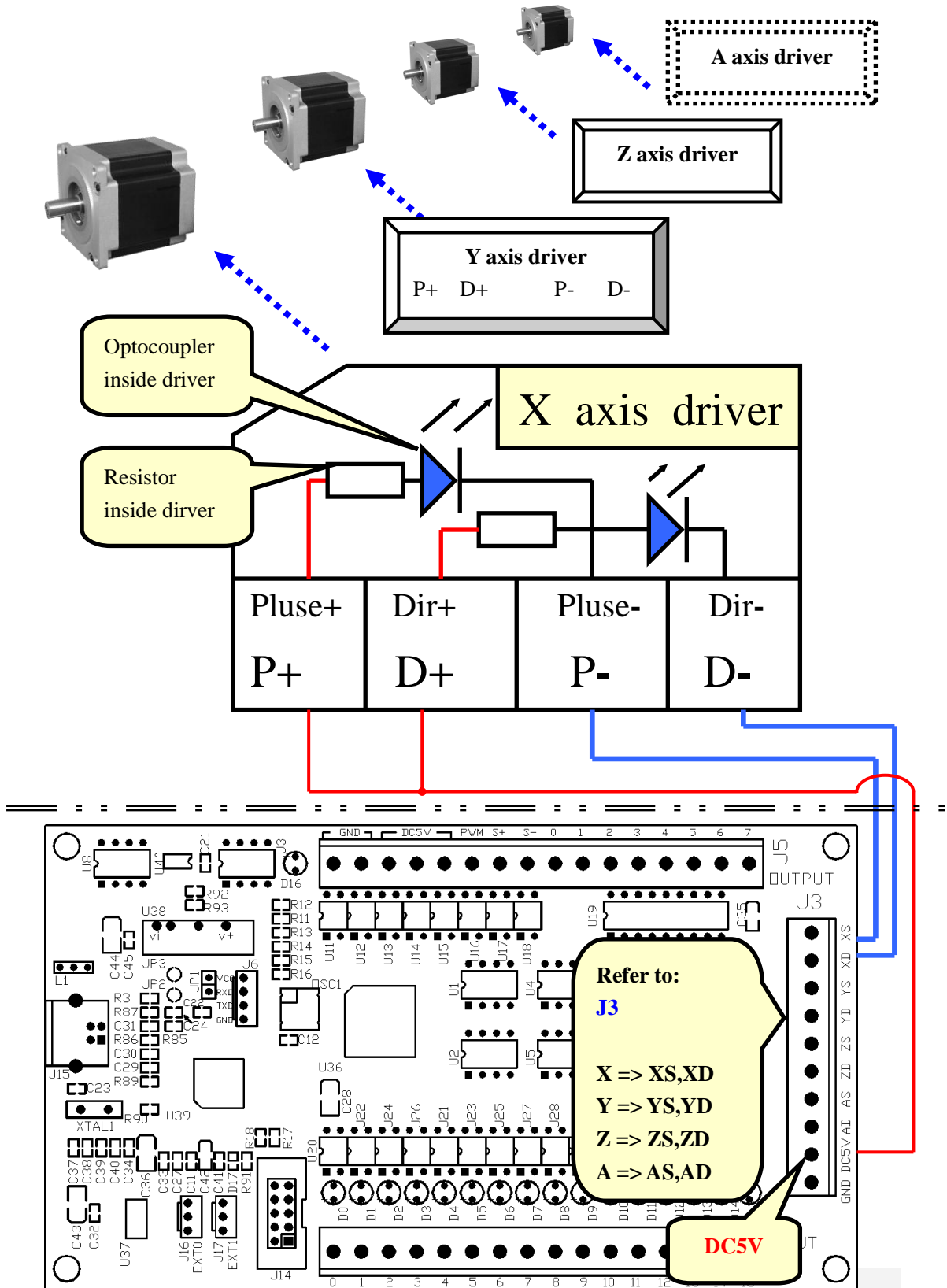

5.1.2 Using External power supply to drive.

Please install suitable resistance according to your setting/servo driver need.

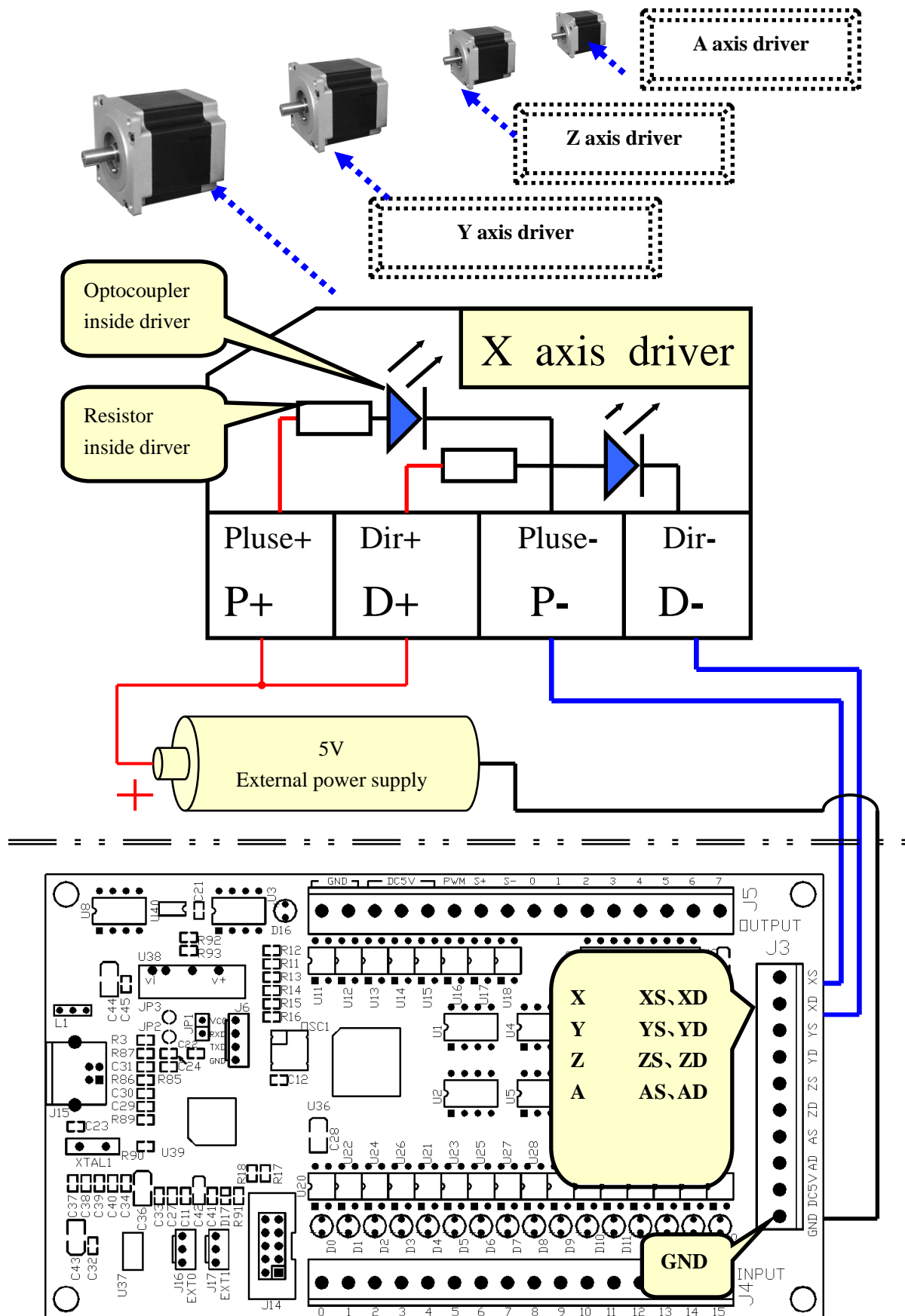

5.2 Input Channels:

There are two methods of voltage power supply: Internal or External

5.2.1 Internal voltage power supply

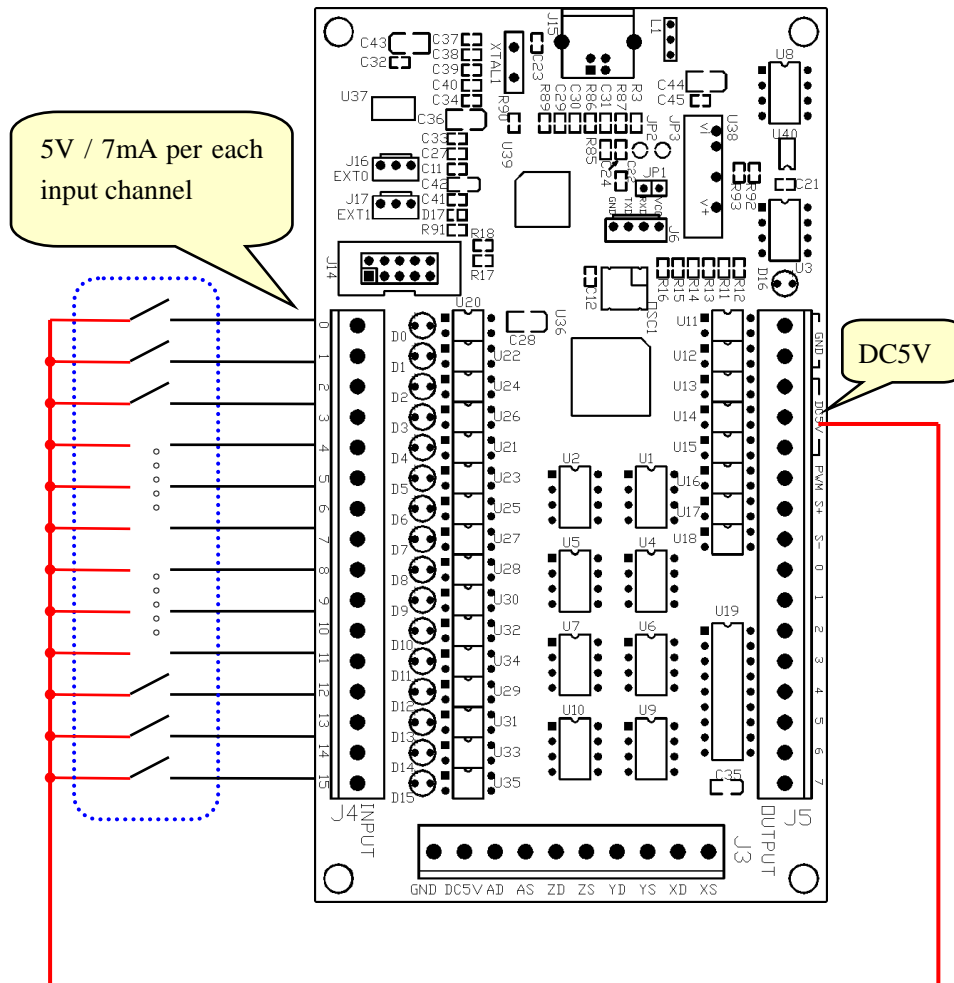

5.2.2 External voltage power supply for input.

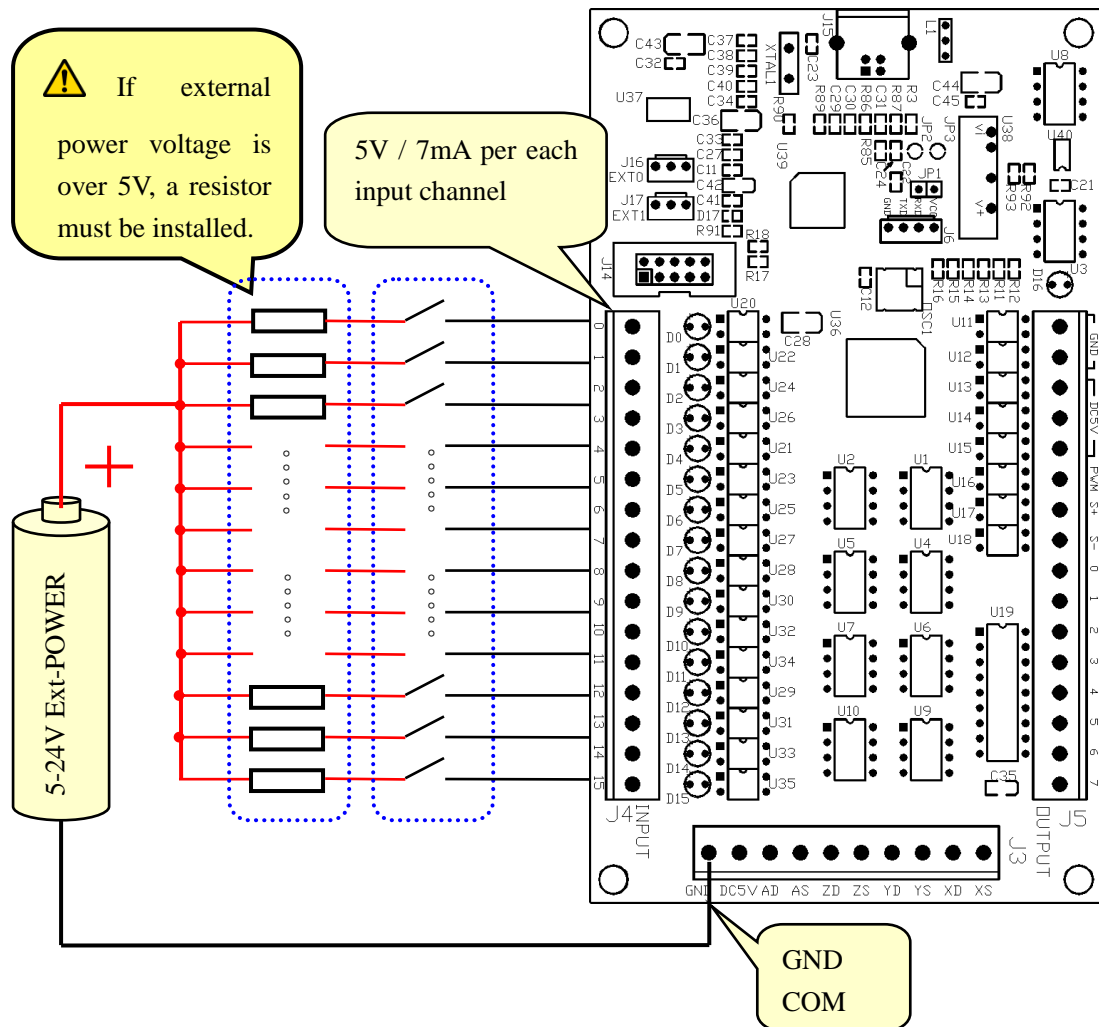

⚠ ATTENTION:

If the external power voltage is over 5V, a resistor must be installed between the power source and each input channel!

For the external power voltage is 24V, 3K Ω resistor must be used,

And for the external power voltage is 12V, 1.5K Ω resistor must be used,

5.3 Sensor's wiring and setting

5.3.1 PNP sensor

⚠ Use the external power supply for the sensor!

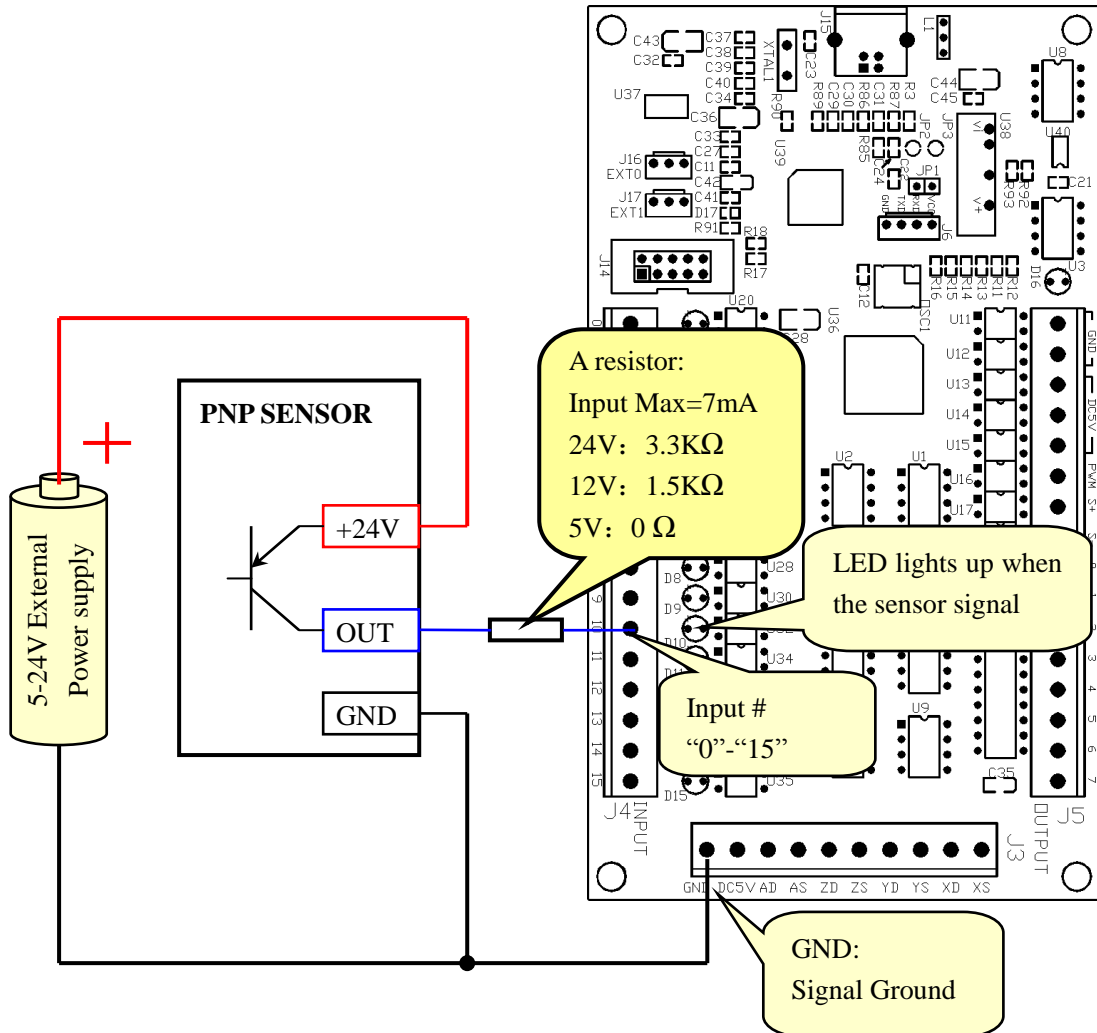

Mach3 Input Signals Setting

Encoder/MPG's		Spindle Setup			Mill Options	
Setup and Axis Selection		Motor Outputs			Input Signals	
					Output Signals	
Enabled	Port #	Pin Number	Active Low	Emulated	HotKey	
<input checked="" type="checkbox"/>	1	10	<input checked="" type="checkbox"/>	<input checked="" type="checkbox"/>	0	

Pick ticks "✓"

From 0 to 15 according to the wiring

⚠ Suggest pick a cross "X" when using a PNP sensor

5.3.2 NPN sensor

⚠ Use the external power supply for the sensor!

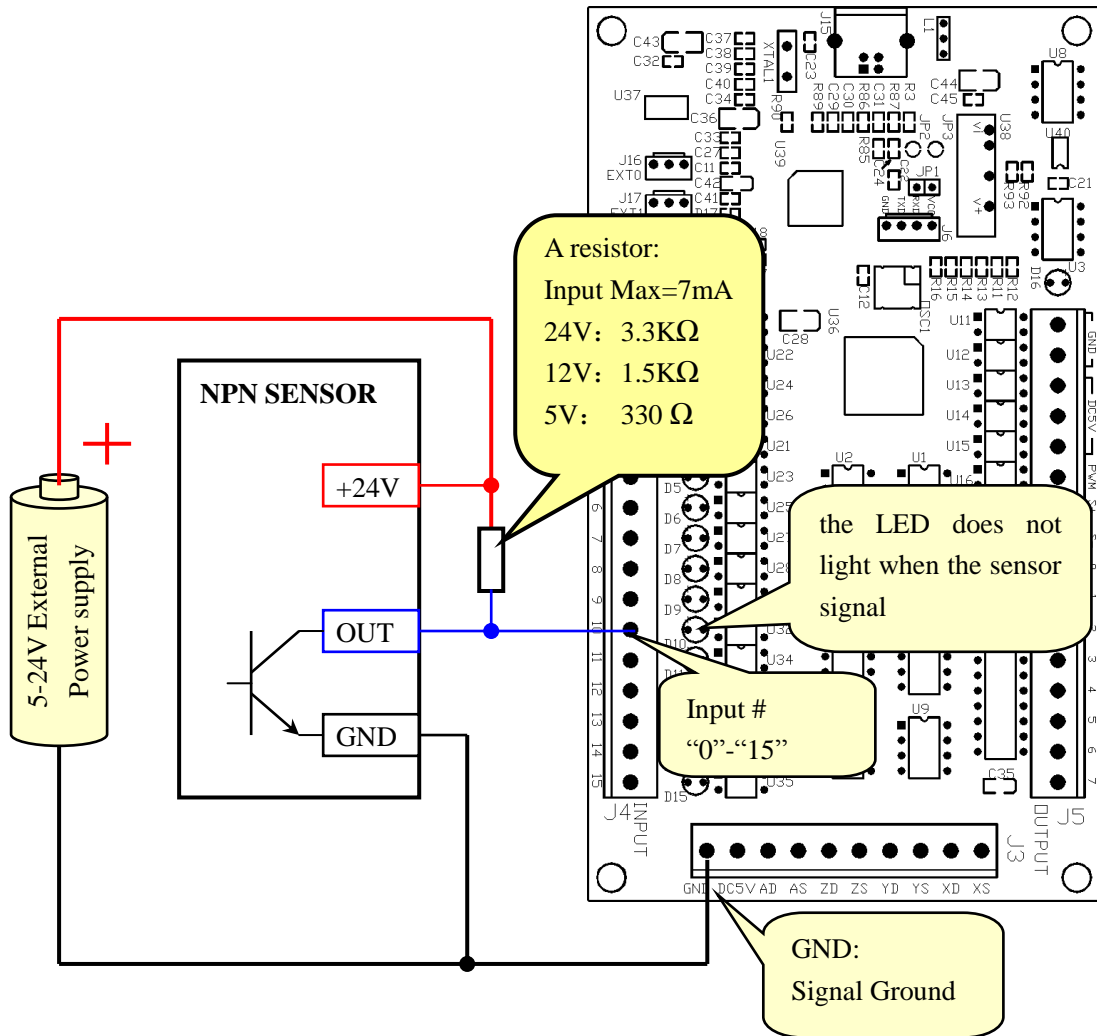

Mach3 Input Signals Setting

Encoder/MPG's		Spindle Setup			Mill Options	
Port Setup and Axis Selection		Motor Outputs			Input Signals	
Port	Enabled	Port #	Pin Number	Active Low	Emulated	HotKey
1	<input checked="" type="checkbox"/>	1	10	<input checked="" type="checkbox"/>	<input checked="" type="checkbox"/>	0

Pick ticks "✓"

From 0 to 15 according to the wiring

⚠ Suggest to put tick "✓" when using a NPN sensor

5.4 output: 8-general-outputs,

Maximum Load voltage=24V / current=500mA, When output Low (turn on), otherwise the output is high-impedance state (Hi-Z).

5.4.1 Drive LED with Internal(On-board) power

When drive tiny current loads like LED, driver enable signal etc, internal (on-board) power supply can be used directly.

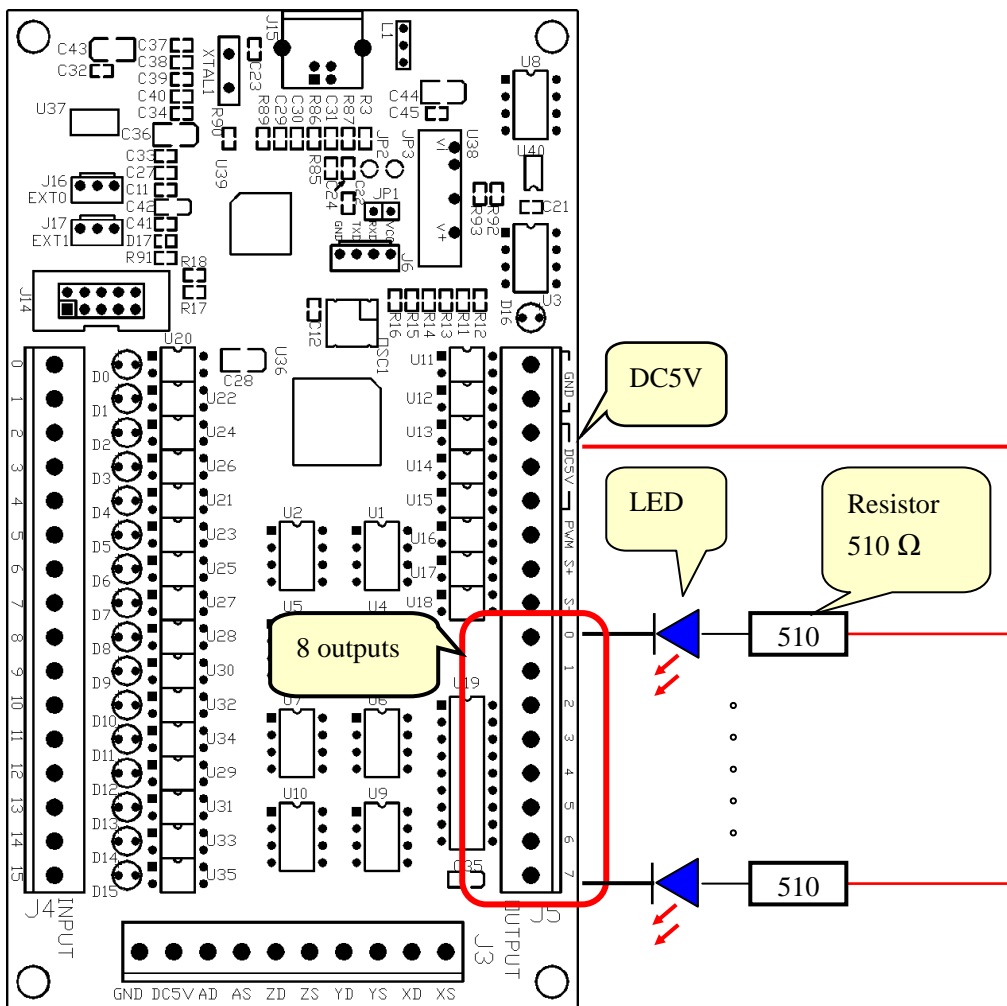

5.4.2 Drive 500mA relay by 5-24V external power supply

Driver high loading devices, must use external power supply

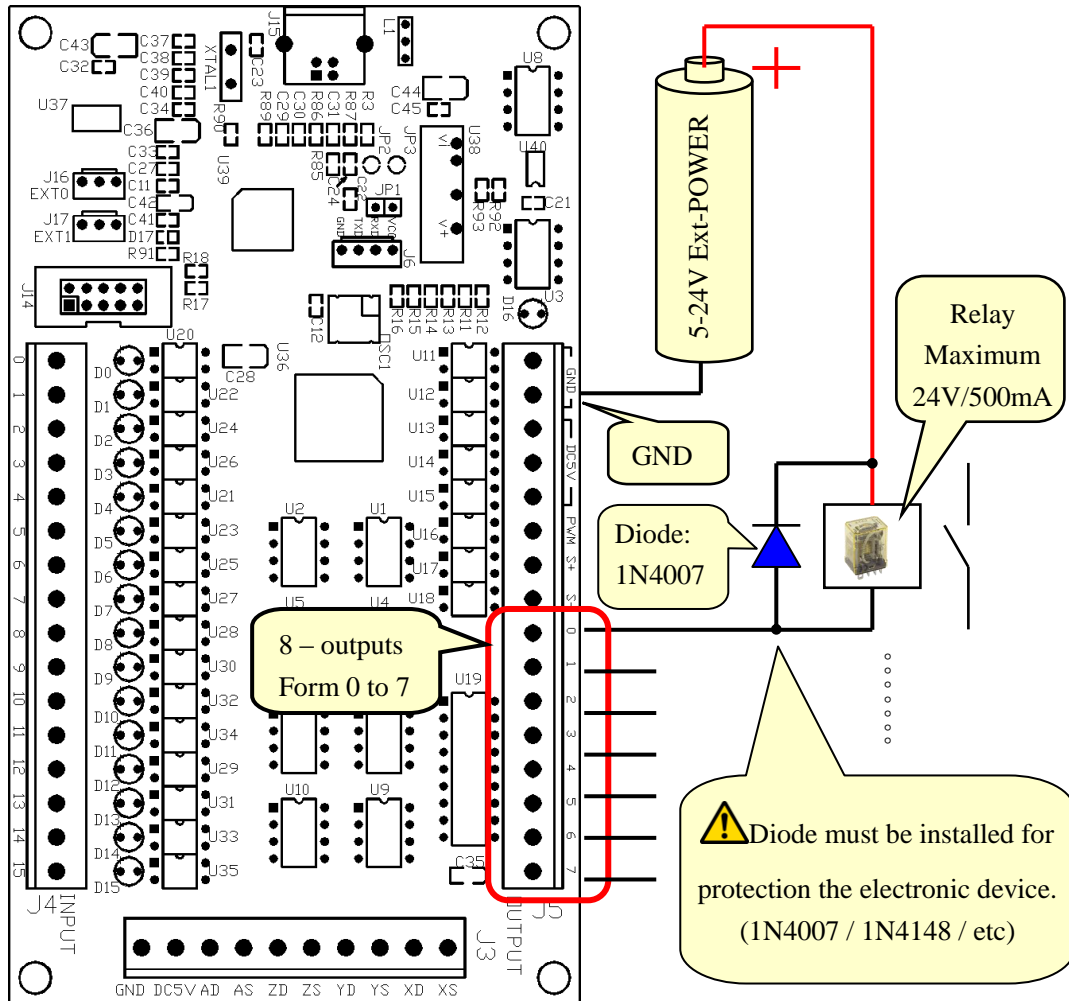

6 Adjustment-knob

6.1 Please complete the step in Chapter 1 (Prepare).

6.2 Connecting the adjustment-knob with the EXT0(J16) of USB Motion Card.

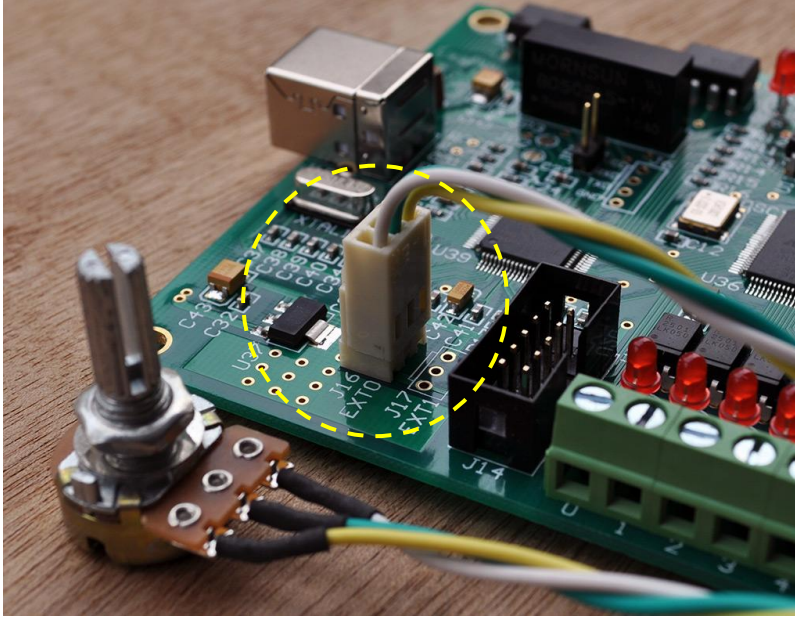

6.3 Go to “Config Plugins” under “Config” to go into “PlugIn Control and Activation”.

PlugIn Control and Activation

Enabled	PlugIn Name	Config
	Flash-FlashScreen-SWF-PlugIn-A. Fenerty--B.-B...	CONFIG
	JoyStick-JoyStick-PlugIn--Art-Fenerty-Ver-1.0a	CONFIG
	PrinterScope-Port-Scope-1.00.046	CONFIG
	ShuttlePro-Contour-Shuttle-Pendants---A. Fene...	CONFIG
	TurnDiags-Turn-Diags-1.00.1	CONFIG
	Xulifeng-Mach3-USB-Motion-Card	CONFIG
	Video---B. Barker-Ver-1.0	CONFIG

After connecting the USB Motion Card, the tick“√”, must be shown, other wise, please check the connection between the Card and computer.

Check “Config”

OK

6.4 After check the “Config”, USB Motion Card setting will be shown. You can select one of the functions which is able to controlled by the external knob. Please select “External 0” in your particular setting. Then, click “OK” to exit.

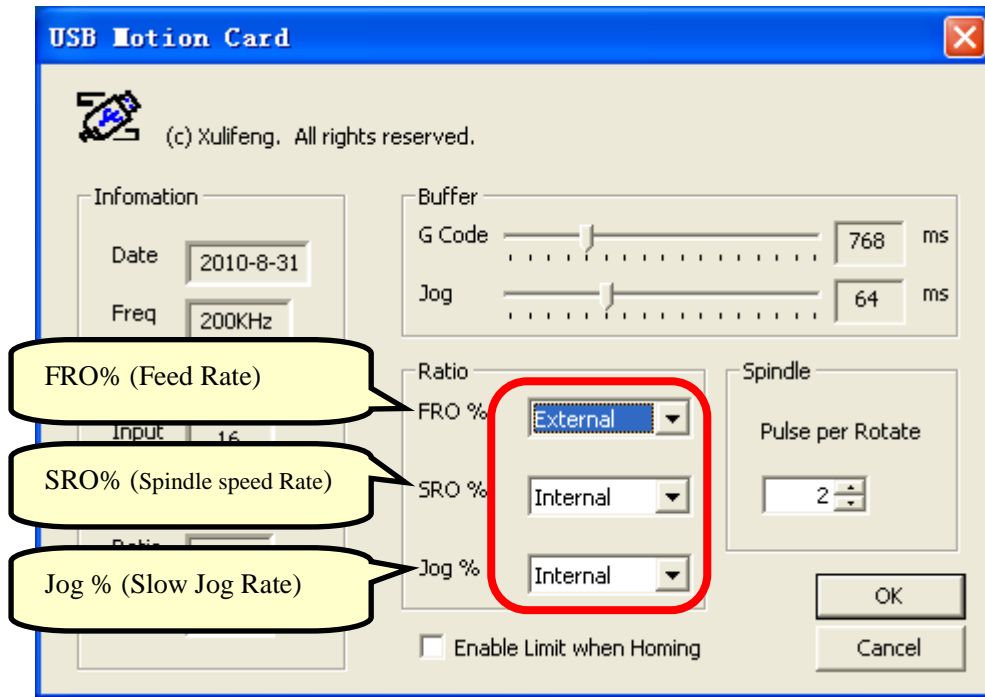

6.5 Now, you can try to turn the knob to adjust your selected function.

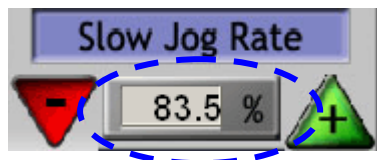
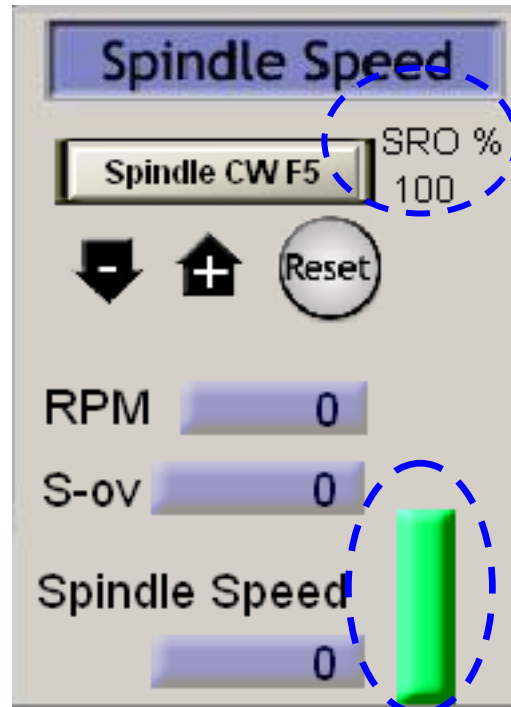
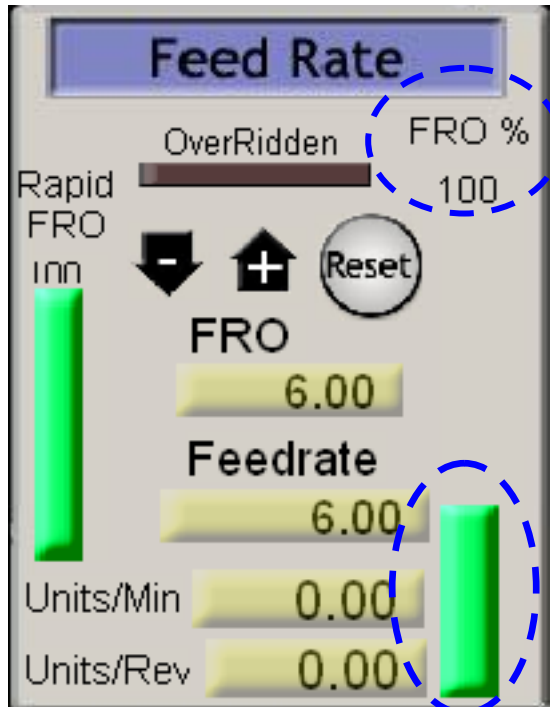

7

7.1

7.1.1 Spindle Setup

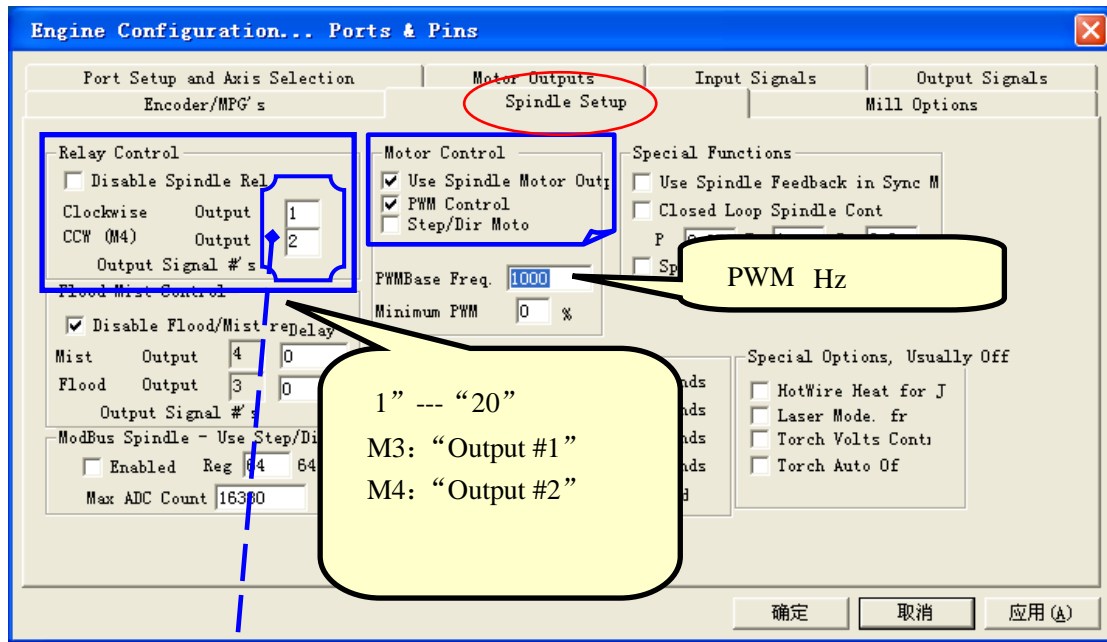

Output Signals” ,
的 “Output #1—Output #20”

7.1.2

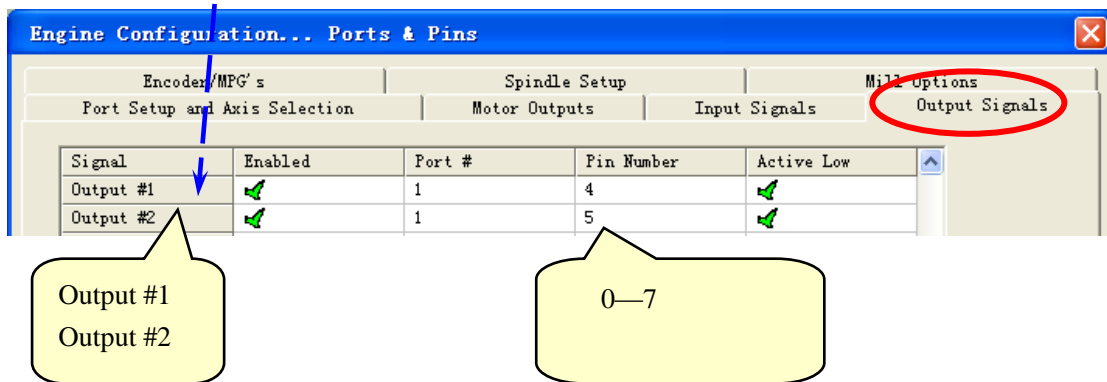

Output #1
Output #2

0—7

7.1.3 PWM

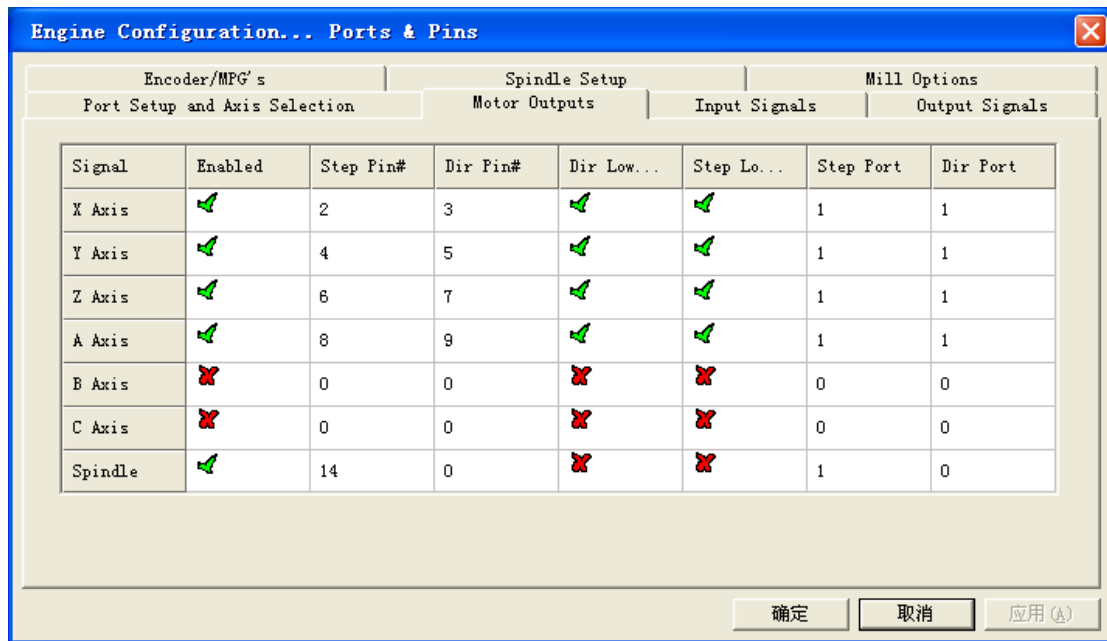

7.1.4 Mach3 "Config=>Spindle Pulleys.." "Pulley Selection"

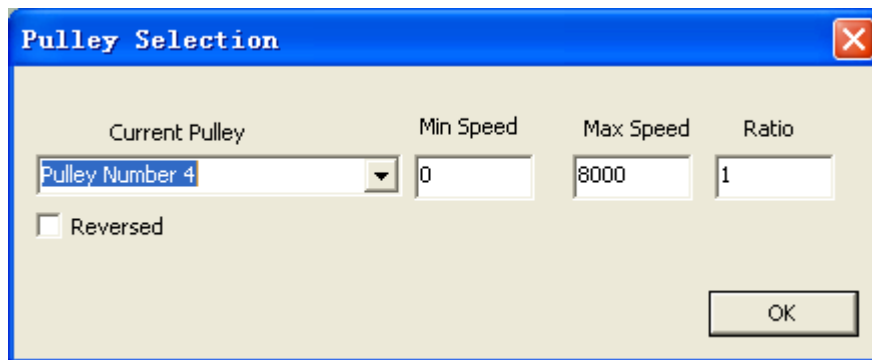

7.2

M3
S10000
M5



7.3

Schematic

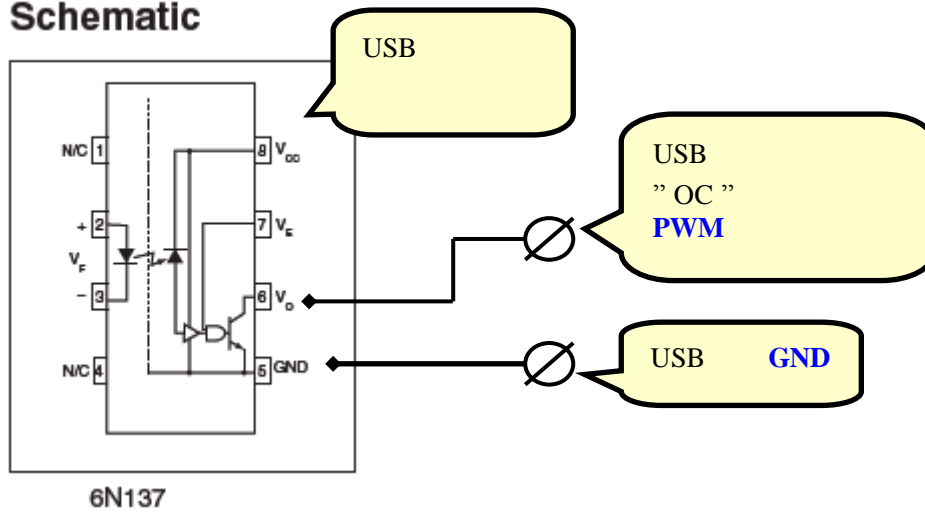

7.4 USB

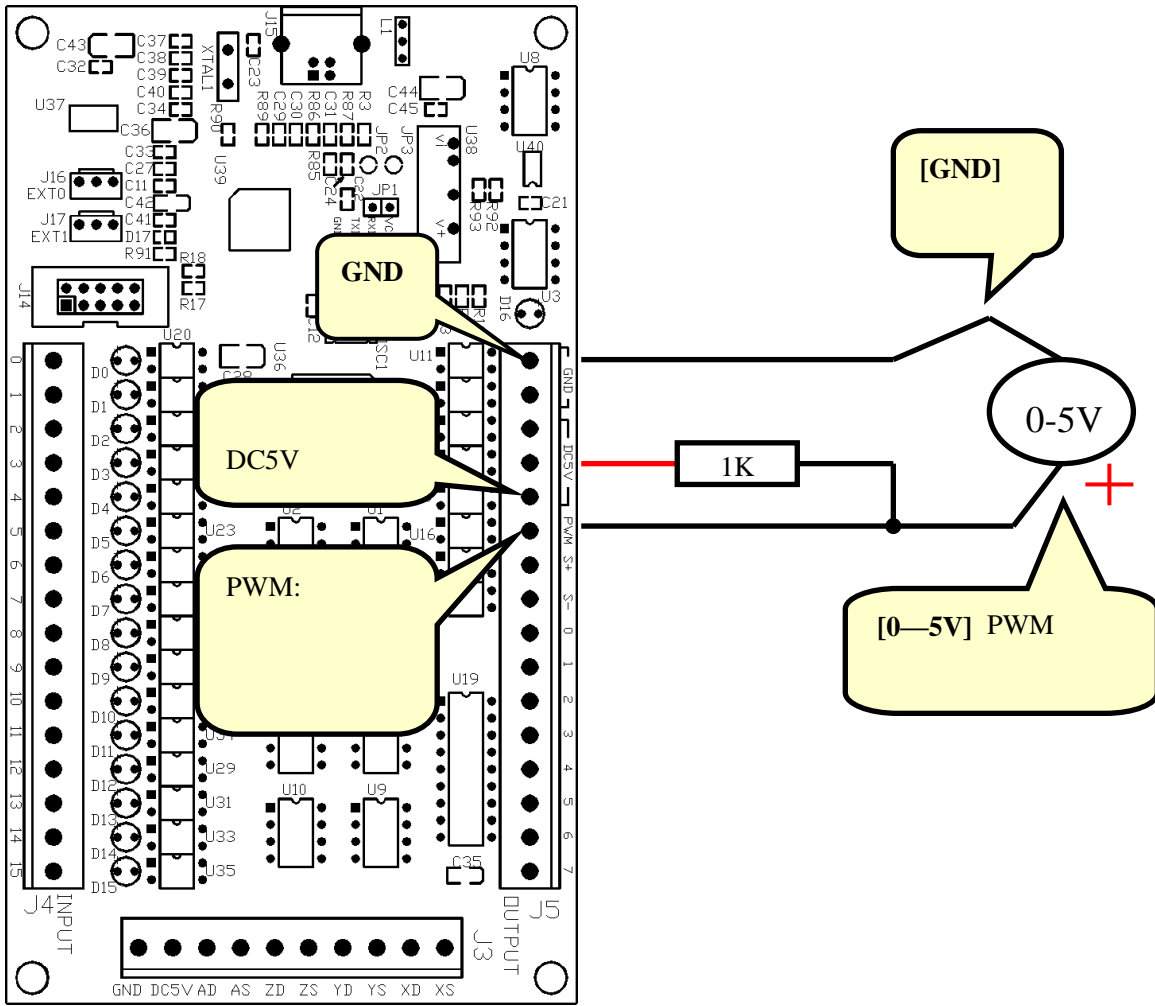

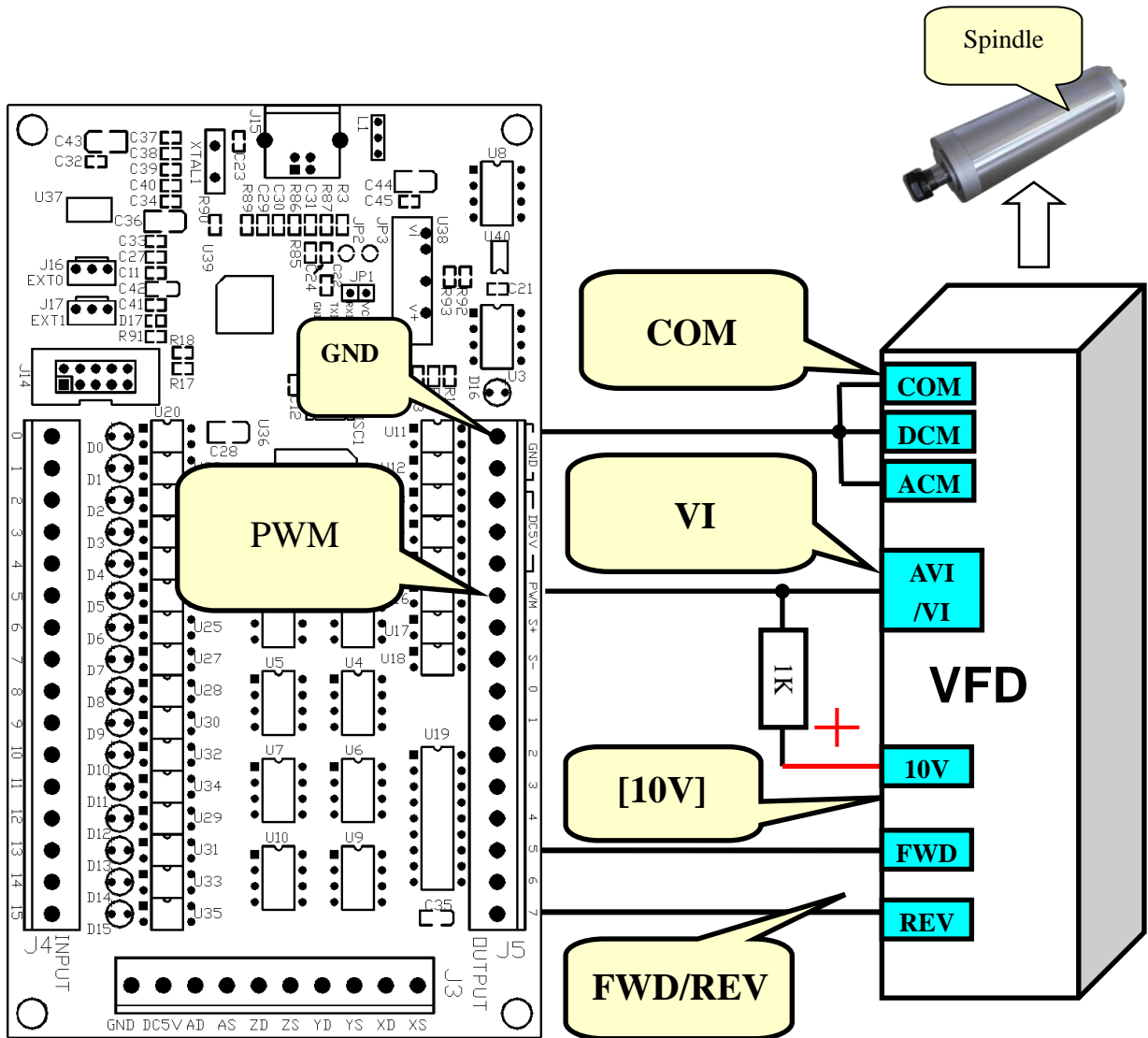

8 Measure the rotating speed of the spindle

8.1 USB Motion Card Configuration dialog

Go to “Config Plugins” under “Config” to go into “PlugIn Control and Activation”.

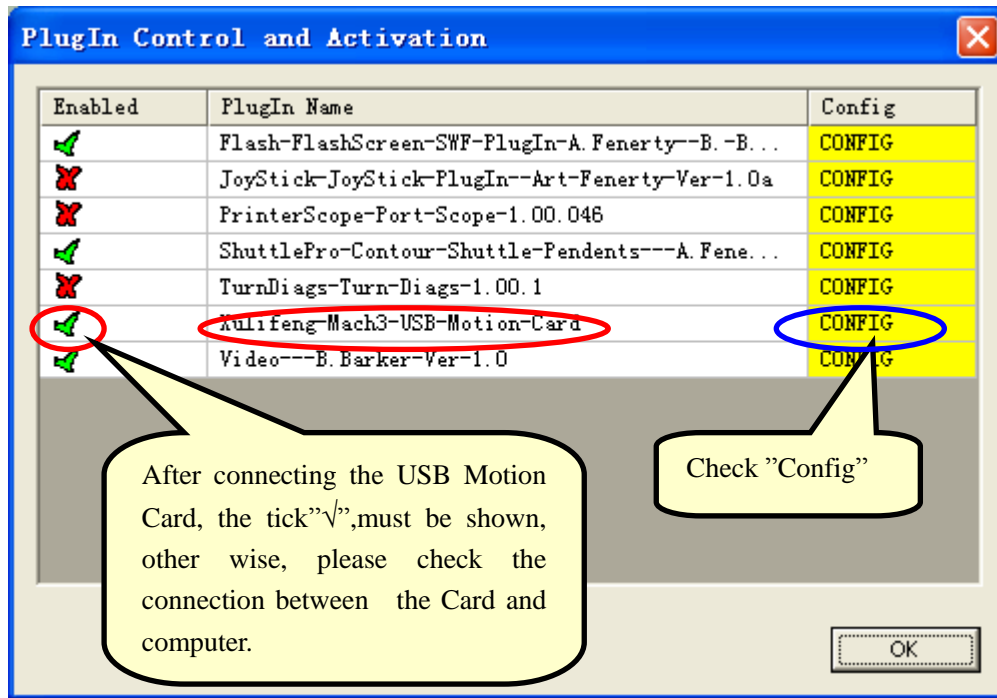

Check the “Config” to entry the “USB Motion Card”

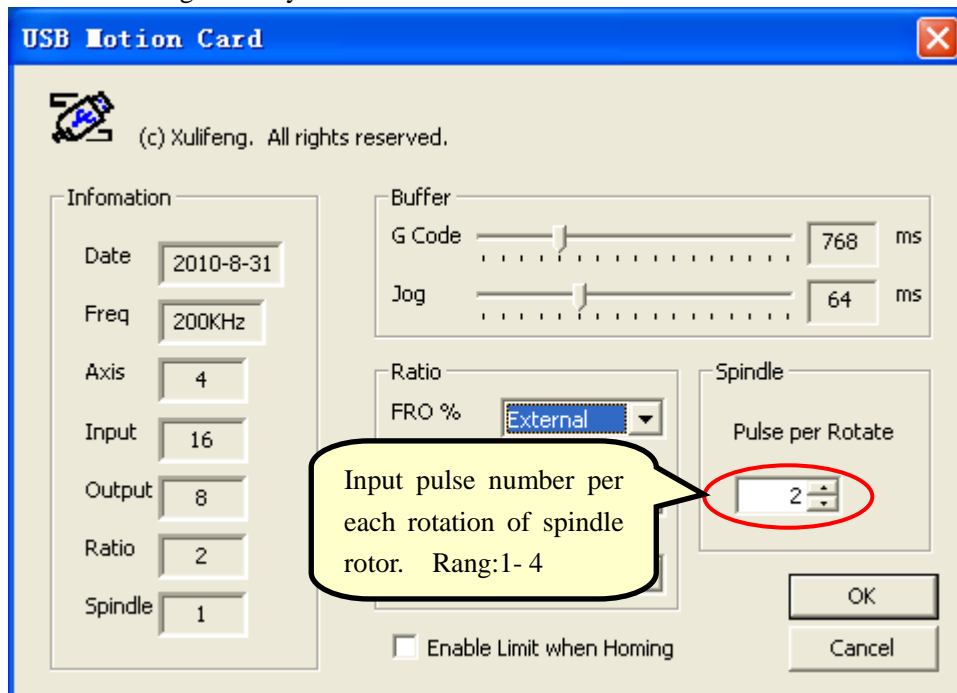

8.2 Show Spindle Speed

Measured speed will be displayed in the Mach3 as shown below

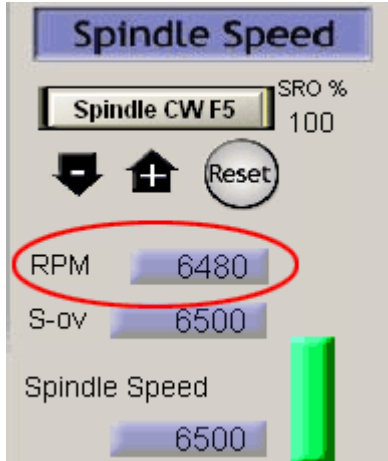

In addition, you can open the spindle speed real-time waveform display

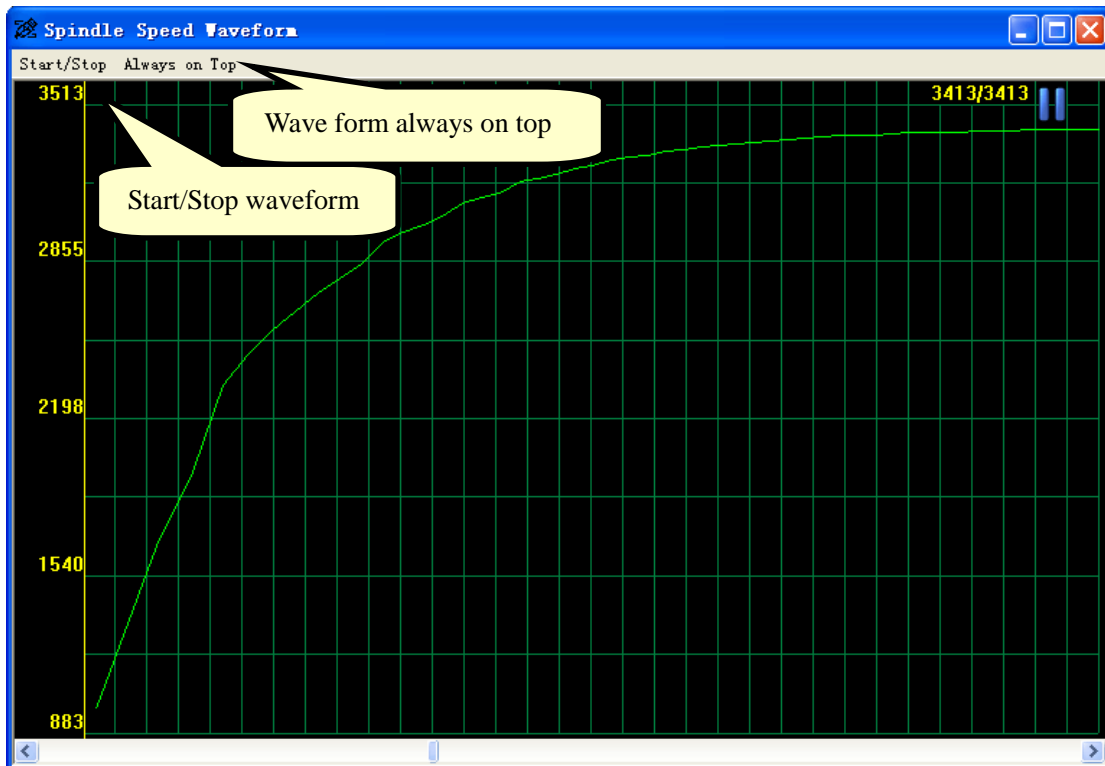

8.3 Hall sensor test circuit

Hall sensor Model "44E", open-drain output (OC).

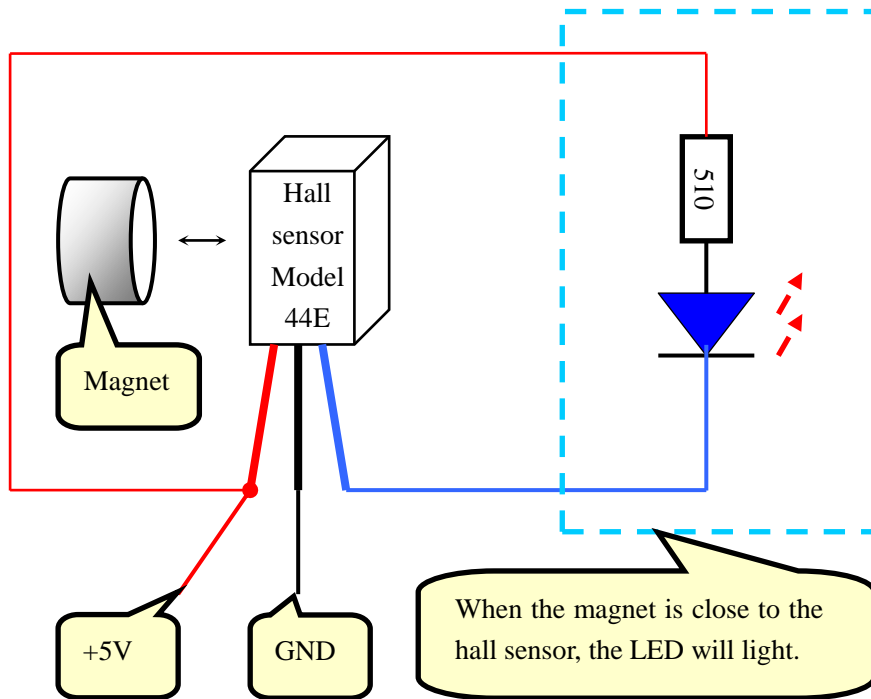

8.4 Hall sensor /Rotation plate install

Note: Be carefully about the direction of the magnetic poles of the magnet.

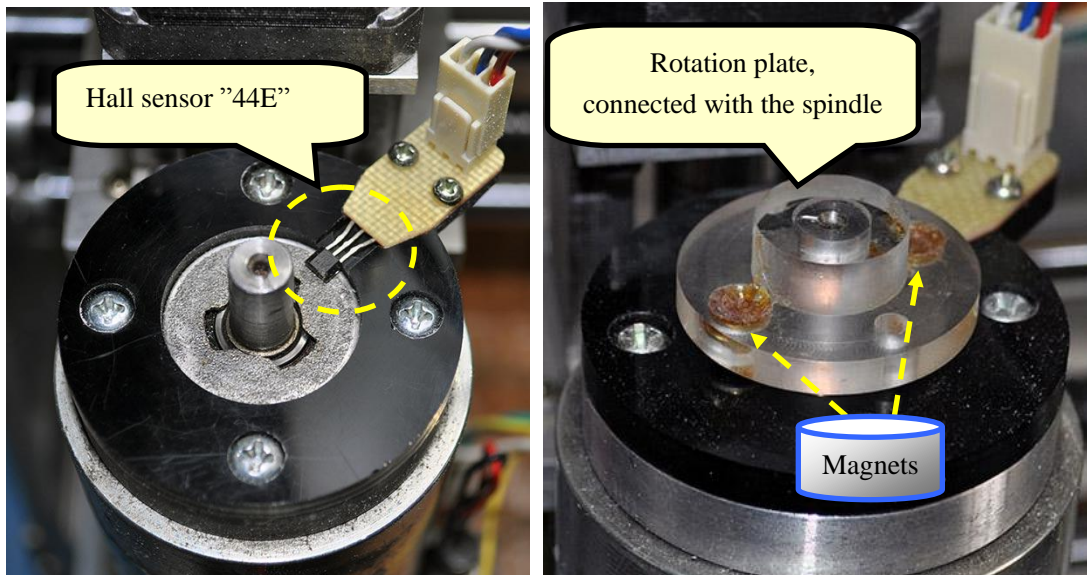

8.5 Diagram of the spindle speed sensor part of the USB Motion Card

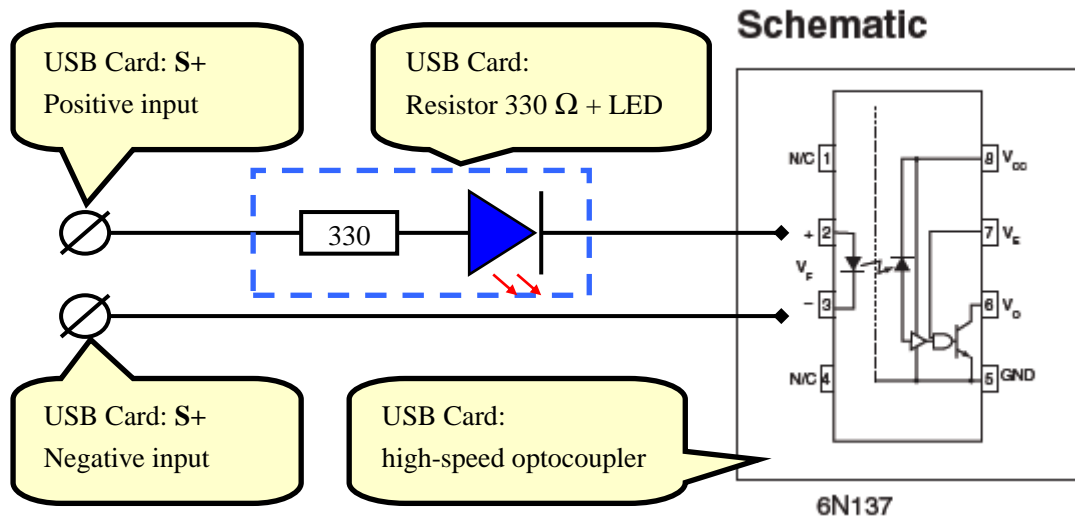

8.6 Connection Diagram of the hall sensor

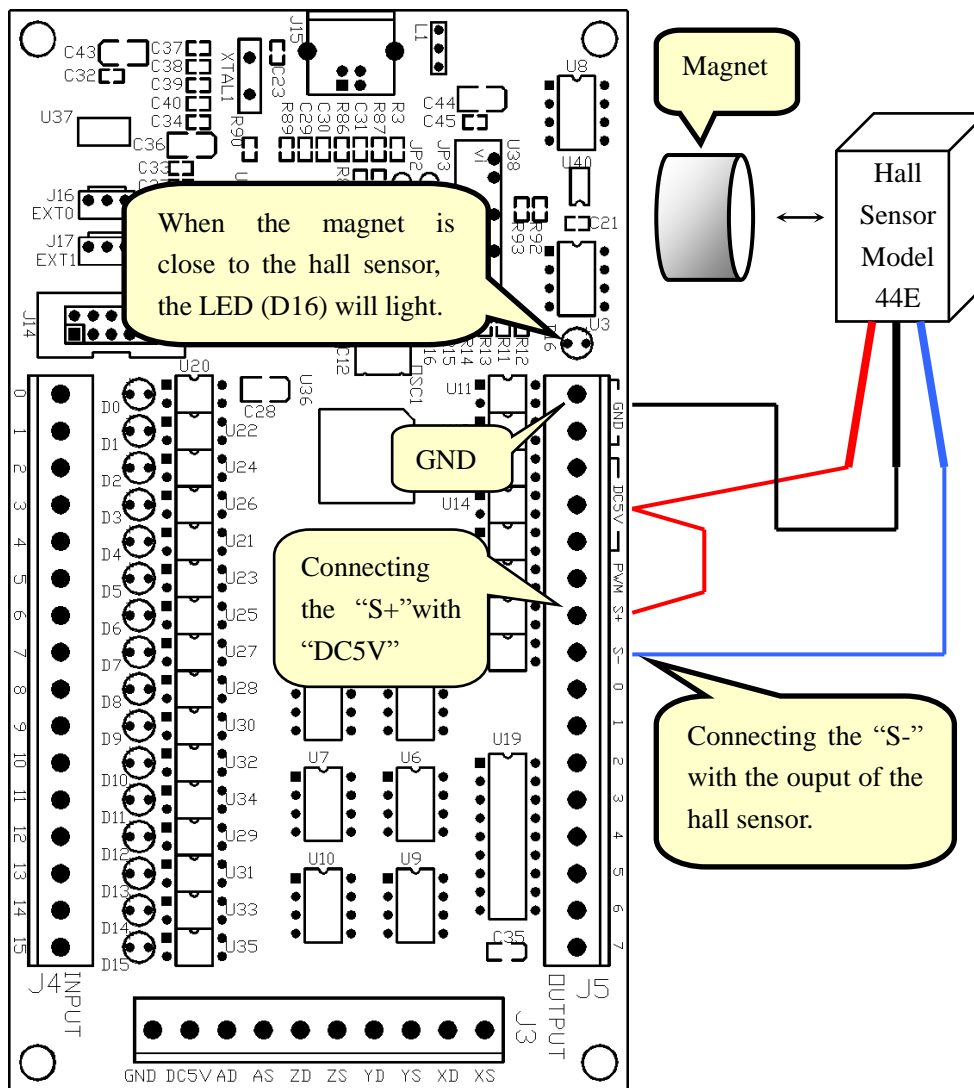

9 Auto tool zero

9.1 Tool touch sensor wires

9.1.1 "one wire" simple tool touch sensor:

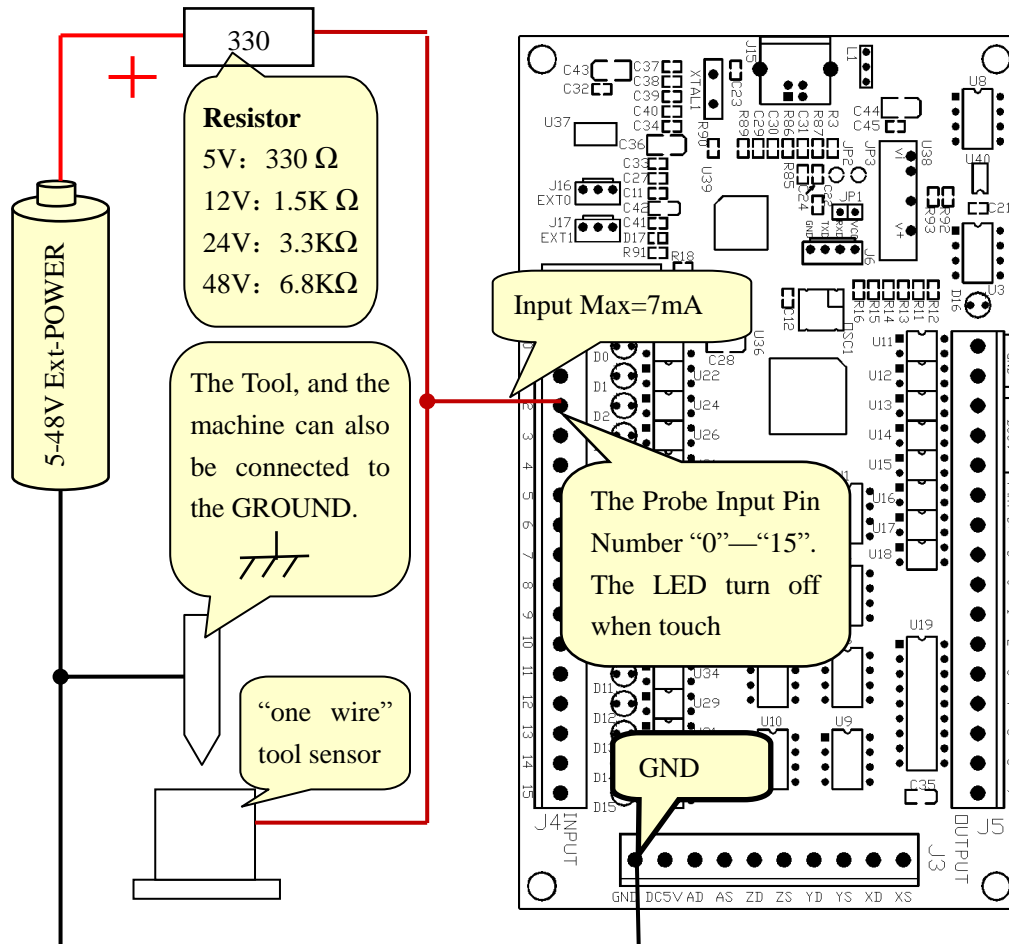

Setup Probe input signal, as shown below: (Config => Ports and Pins)

Signal	Enabled	Port #	Pin Number	Active Low	Emulated	HotKey
Input #2	<input checked="" type="checkbox"/>	1	0	<input checked="" type="checkbox"/>	<input checked="" type="checkbox"/>	0
Input #3	<input checked="" type="checkbox"/>	1	0	<input checked="" type="checkbox"/>	<input checked="" type="checkbox"/>	0
Input #4	<input checked="" type="checkbox"/>	1	0	<input checked="" type="checkbox"/>	<input checked="" type="checkbox"/>	0
Probe	<input checked="" type="checkbox"/>	1	2	<input checked="" type="checkbox"/>	<input checked="" type="checkbox"/>	0
Index	<input checked="" type="checkbox"/>	1	0	<input checked="" type="checkbox"/>	<input checked="" type="checkbox"/>	0
Limit Over	<input checked="" type="checkbox"/>	1	0	<input checked="" type="checkbox"/>	<input checked="" type="checkbox"/>	0
ES	<input checked="" type="checkbox"/>	1	10	<input checked="" type="checkbox"/>	<input checked="" type="checkbox"/>	0

Pick tick "✓" Turn on Probe

"0"—"15" Depend on wires

Pick tick "✓" Pick tick "✓"

9.1.2 “two-wire” Tool touch sensor:

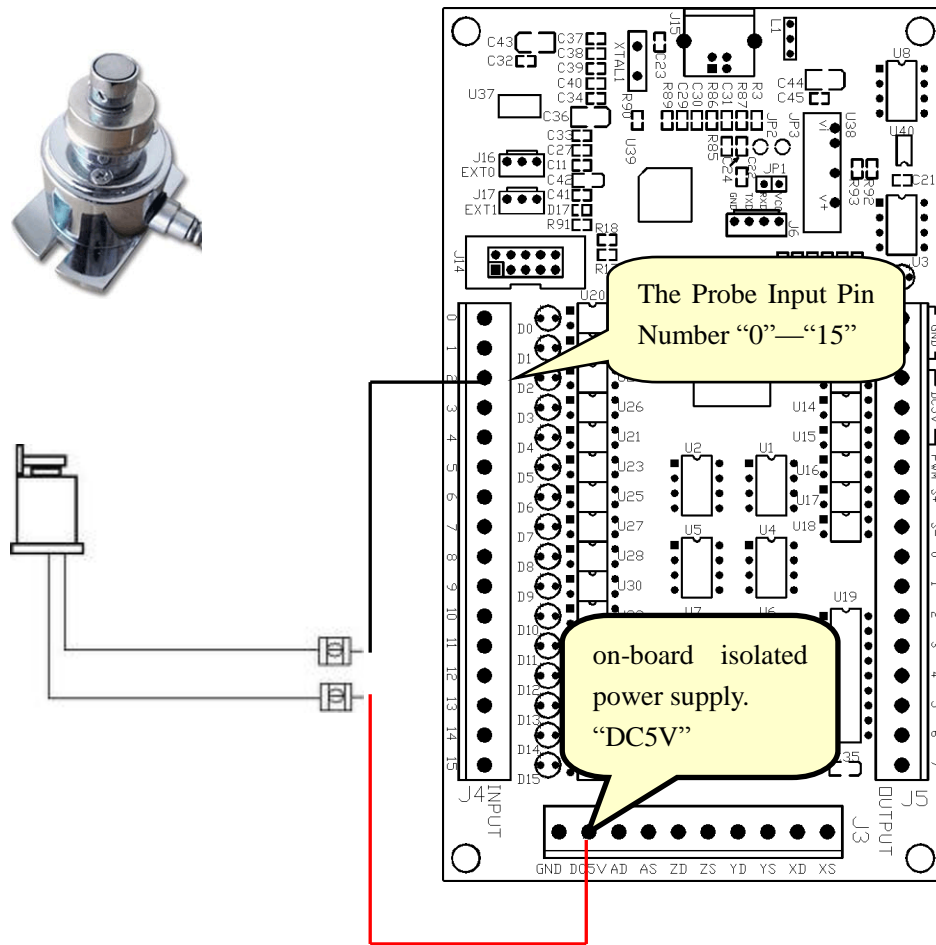

Setup Probe input signal, as shown below: (Config => Ports and Pins)

Engine Configuration... Ports & Pins

Signal	Enabled	Port #	Pin Number	Active Low	Emulated	HotKey
Input #2	<input checked="" type="checkbox"/>	1	0	<input checked="" type="checkbox"/>	<input checked="" type="checkbox"/>	0
Input #3	<input checked="" type="checkbox"/>	1	0	<input checked="" type="checkbox"/>	<input checked="" type="checkbox"/>	0
Input #4	<input checked="" type="checkbox"/>	1	0	<input checked="" type="checkbox"/>	<input checked="" type="checkbox"/>	0
Probe	<input checked="" type="checkbox"/>	1	2	<input checked="" type="checkbox"/>	<input checked="" type="checkbox"/>	0
Index	<input checked="" type="checkbox"/>	1	0	<input checked="" type="checkbox"/>	<input checked="" type="checkbox"/>	0
Limit Ovrdr	<input checked="" type="checkbox"/>	1	0	<input checked="" type="checkbox"/>	<input checked="" type="checkbox"/>	0
EStop	<input checked="" type="checkbox"/>	1	0	<input checked="" type="checkbox"/>	<input checked="" type="checkbox"/>	0

Pins 10-13 and 15 are inputs. Only these 5 pin numbers may be

Automated Setup of Inputs

Callouts:
 - "Pick ticks" ✓ " Turn on Probe" (points to Enabled column)
 - "0"—"15" Depend on wires" (points to Pin Number column)
 - "Pick a cross "X" (points to Active Low column)

9.2 Loading the VB Script to the Auto Tool Zero Button

That Mach3 provides for customizable, user-defined button macros on some of the existing screen buttons is what makes this possible without having to do Mach3 screen designs to add new buttons. The Auto Tool Zero button on the Programs Run screen is the one used for this purpose.

9.2.1 From the Mach3 Program Run screen, click “Operator” on the Menu bar

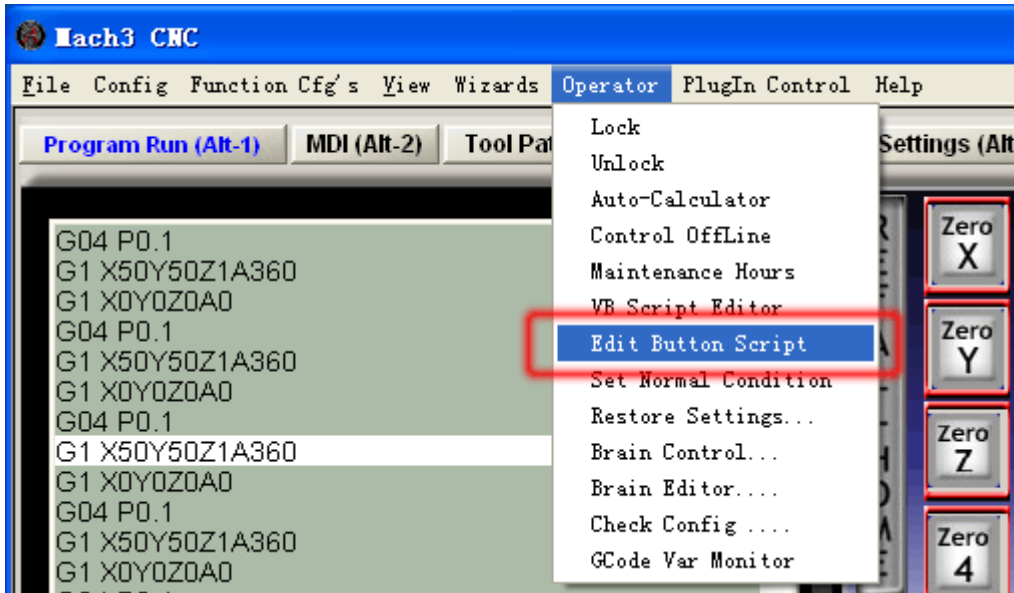

9.2.2 then click “Edit Button Script”. The buttons that are editable will start flashing.

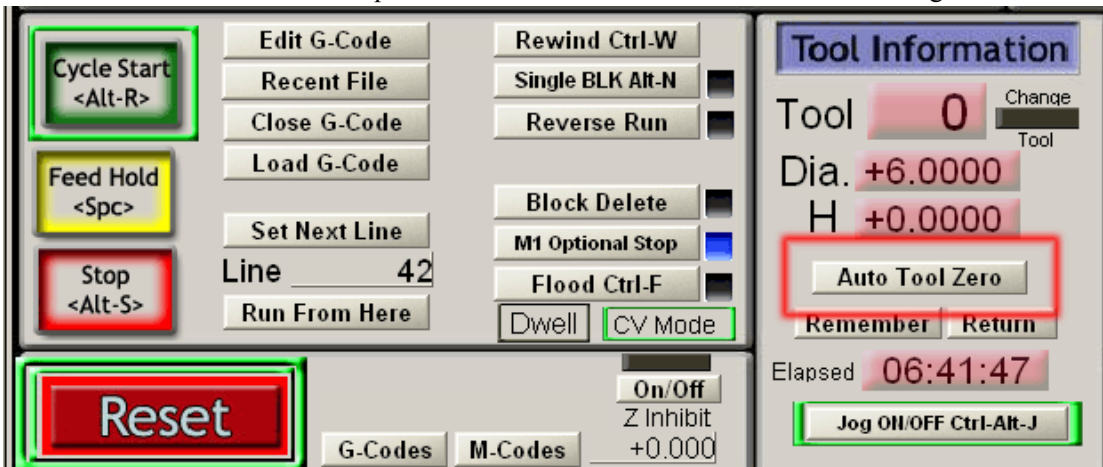

9.2.3 click the flashing Auto Tool Zero button. The Mach3 VB Script Editor window will open. By default this file will always be named "HiddenScript.m1s and at first there is one line of code in the edit window that may have a “Not Implemented” message in it.

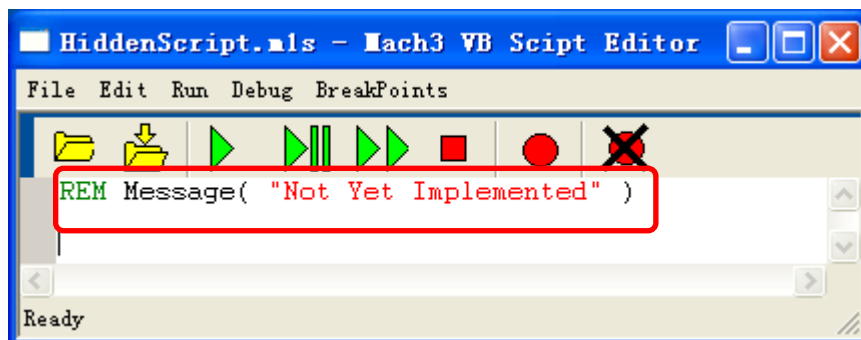

9.2.4 Click any where in the edit window's white space. Highlight any lines by typing Ctrl+A and press the Delete key or click Edit > Select All > press Delete key.

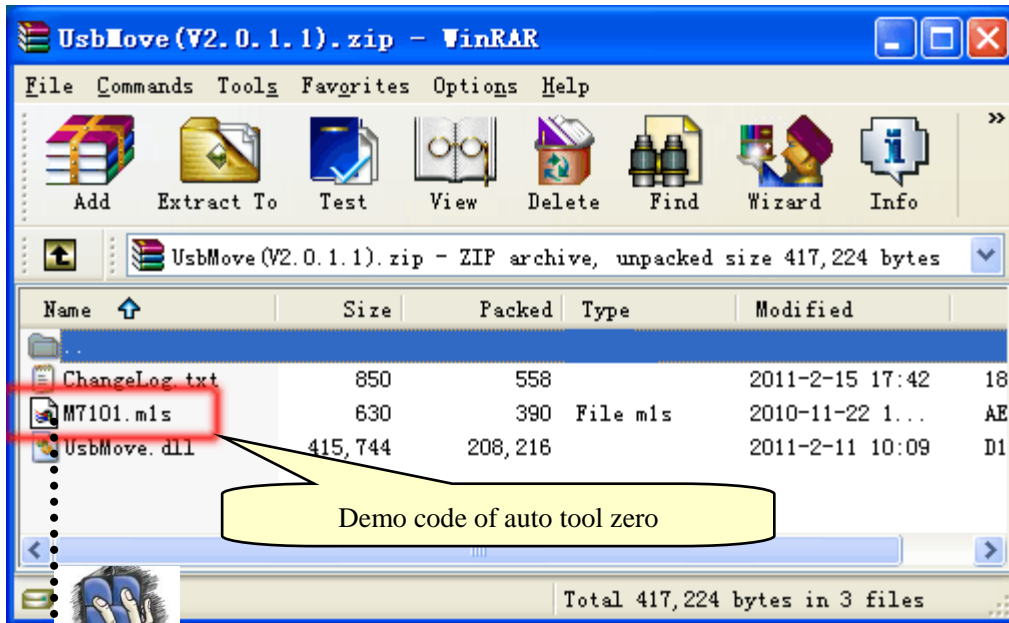

Drag "M7101.mls" to Notepad

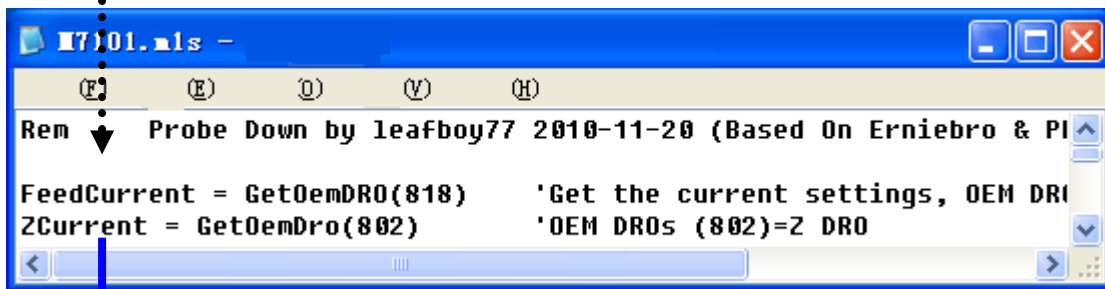

Copy all of the lines in the script from this document

Paste them into the VB Script Editor window then click File > Save.

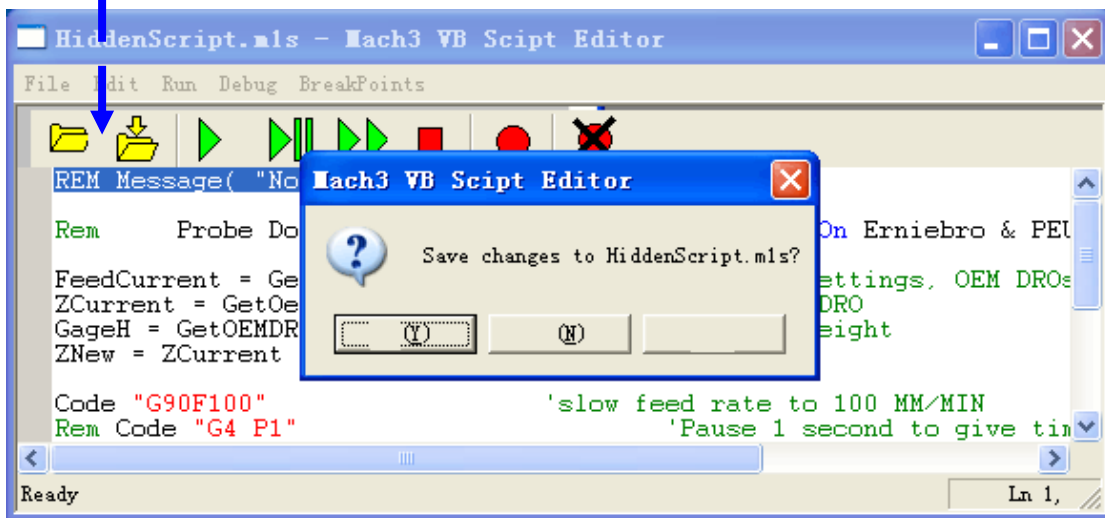

9.2.5 Note: <http://buildyourtools.com/phpBB3/viewtopic.php?f=5&t=985>

10.2

10.2.1 Mach3 (Config => Ports and Pins)

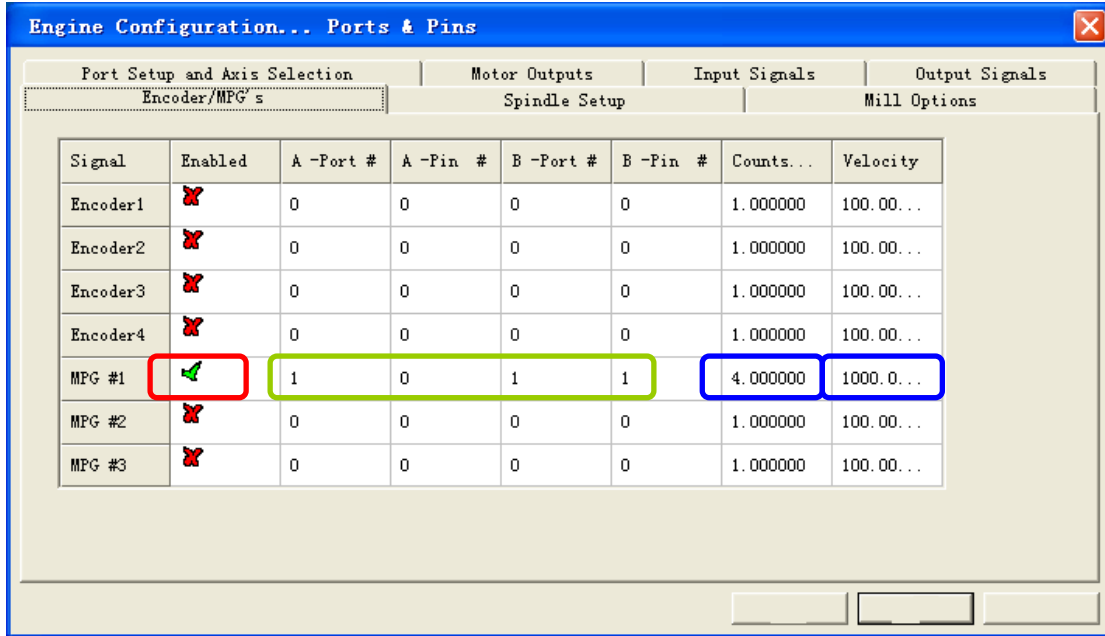

10.2.2 "TAB"

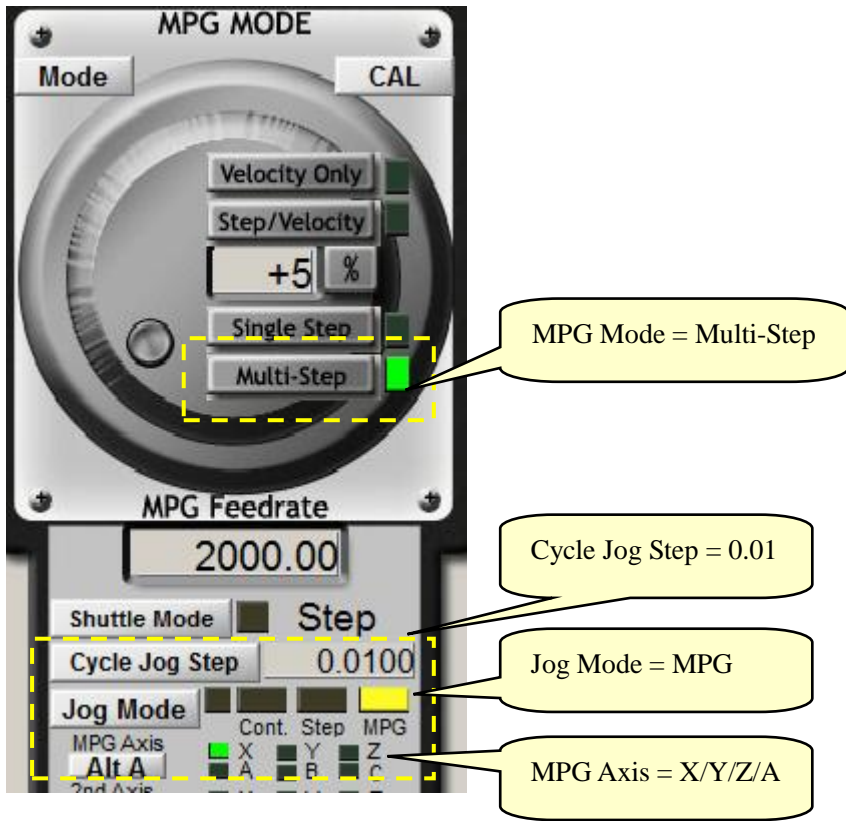

11 Read-ahead buffer setting

11.1 Go to “Config Plugins” under “Config” to go into “PlugIn Control and Activation”.

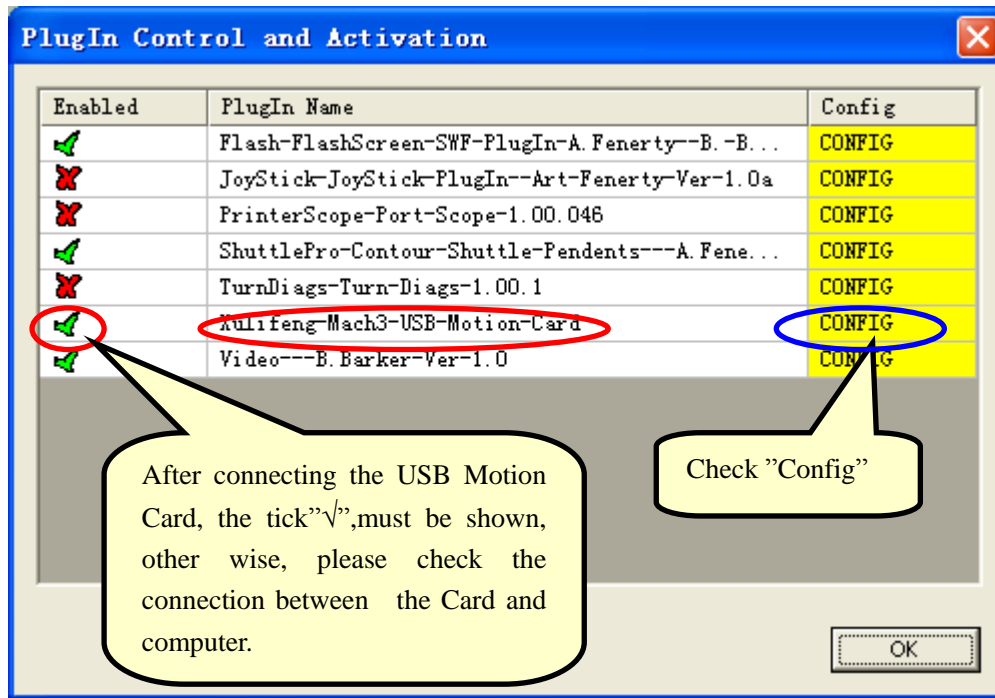

11.2 In accordance with the performance of a PC, set the read-ahead buffer. Adjust the buffer time to run smoothly.

